

FLASH MEMORY

CMOS

4M (512K × 8) BIT

MBM29LV004T-10/-12/MBM29LV004B-10/-12

■ FEATURES

- **Single 3.0 V read, program, and erase**
Minimizes system level power requirements
- **Compatible with JEDEC-standard commands**
Uses same software commands as E²PROMs
- **Compatible with JEDEC-standard world-wide pinouts**
40-pin TSOP (Package suffix: PTN – Normal Bend Type, PTR – Reversed Bend Type)
40-pin SON (Package suffix: PNS)
- **Minimum 100,000 write/erase cycles**
- **High performance**
100 ns maximum access time
- **Sector erase architecture**
One 16K byte, two 8K bytes, one 32K byte, and seven 64K bytes.
Any combination of sectors can be concurrently erased. Also supports full chip erase.
- **Boot Code Sector Architecture**
T = Top sector
B = Bottom sector
- **Embedded Erase™ Algorithms**
Automatically pre-programs and erases the chip or any sector
- **Embedded Program™ Algorithms**
Automatically writes and verifies data at specified address
- **Data Polling and Toggle Bit feature for detection of program or erase cycle completion**
- **Ready-Busy output (RY/BY)**
Hardware method for detection of program or erase cycle completion
- **Automatic sleep mode**
When addresses remain stable, automatically switch themselves to low power mode.
- **Low V_{CC} write inhibit ≤ 2.5 V**
- **Erase Suspend/Resume**
Suspends the erase operation to allow a read in another sector within the same device
- **Sector protection**
Hardware method disables any combination of sectors from program or erase operations.
- **Temporary sector unprotection**
Hardware method enables temporarily any combination of sectors from program or erase operations.

MBM29LV004T-10/-12/MBM29LV004B-10/-12

■ PACKAGE

40-pin Plastic TSOP (I)

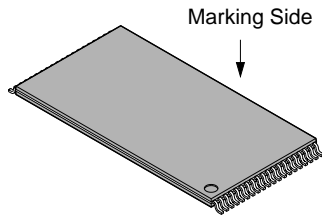

(FPT-40P-M06)

40-pin Plastic SON

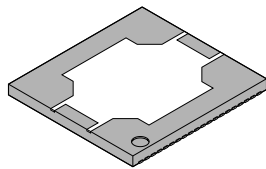

(LCC-40P-M02)

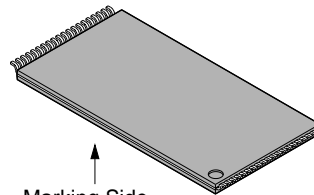

(FPT-40P-M07)

46-pin Plastic SON

MBM29LV004T-10/-12/MBM29LV004B-10/-12

■ DESCRIPTION

The MBM29LV004T/B are a 4M-bit, 3.0 V-only Flash memory organized as 512K bytes of 8 bits each. The MBM29LV004T/B are offered in 40-pin TSOP and 40-pin SON packages. These devices are designed to be programmed in-system with the standard system 3.0 V V_{CC} supply. 12.0 V V_{PP} and 5.0 V V_{CC} are not required for write or erase operations. The devices can also be reprogrammed in standard EPROM programmers.

The standard MBM29LV004T/B offer access times 100 ns and 120 ns, allowing operation of high-speed microprocessors without wait states. To eliminate bus contention the devices have separate chip enable (\overline{CE}), write enable (\overline{WE}), and output enable (\overline{OE}) controls.

The MBM29LV004T/B are pin and command set compatible with JEDEC standard E²PROMs. Commands are written to the command register using standard microprocessor write timings. Register contents serve as input to an internal state-machine which controls the erase and programming circuitry. Write cycles also internally latch addresses and data needed for the programming and erase operations. Reading data out of the devices is similar to reading from 5.0 V and 12.0 V Flash or EPROM devices.

The MBM29LV004T/B are programmed by executing the program command sequence. This will invoke the Embedded Program Algorithm which is an internal algorithm that automatically times the program pulse widths and verifies proper cell margin. Typically, each sector can be programmed and verified in about 0.5 seconds. Erase is accomplished by executing the erase command sequence. This will invoke the Embedded Erase Algorithm which is an internal algorithm that automatically preprograms the array if it is not already programmed before executing the erase operation. During erase, the device automatically times the erase pulse widths and verifies proper cell margin.

A sector is typically erased and verified in 1.0 second. (If already completely preprogrammed.)

These devices also feature a sector erase architecture. The sector mode allows each sector to be erased and reprogrammed without affecting other sectors. The MBM29LV004T/B are erased when shipped from the factory.

The devices feature single 3.0 V power supply operation for both read and write functions. Internally generated and regulated voltages are provided for the program and erase operations. A low V_{CC} detector automatically inhibits write operations on the loss of power. The end of program or erase is detected by \overline{Data} Polling of DQ_7 , by the Toggle Bit feature on DQ_6 , or the RY/\overline{BY} output pin. Once the end of a program or erase cycle has been completed, the devices internally reset to the read mode.

Fujitsu's Flash technology combines years of EPROM and E²PROM experience to produce the highest levels of quality, reliability, and cost effectiveness. The MBM29LV004T/B memories electrically erase the entire chip or all bits within a sector simultaneously via Fowler-Nordhiem tunneling. The bytes/words are programmed one byte/word at a time using the EPROM programming mechanism of hot electron injection.

MBM29LV004T-10/-12/MBM29LV004B-10/-12

■ FLEXIBLE SECTOR-ERASE ARCHITECTURE

- One 16K byte, two 8K bytes, one 32K byte, and seven 64K bytes.
- Individual-sector, multiple-sector, or bulk-erase capability.
- Individual or multiple-sector protection is user definable.

16K byte	7FFFFH
8K byte	7BFFFH
8K byte	79FFFH
32K byte	77FFFH
64K byte	6FFFFH
64K byte	5FFFFH
64K byte	4FFFFH
64K byte	3FFFFH
64K byte	2FFFFH
64K byte	1FFFFH
64K byte	0FFFFH
64K byte	00000H

MBM29LV004T Sector Architecture

64K byte	7FFFFH
64K byte	6FFFFH
64K byte	5FFFFH
64K byte	4FFFFH
64K byte	3FFFFH
64K byte	2FFFFH
64K byte	1FFFFH
64K byte	0FFFFH
32K byte	07FFFH
8K byte	05FFFH
8K byte	03FFFH
16K byte	00000H

MBM29LV004B Sector Architecture

MBM29LV004T-10/-12/MBM29LV004B-10/-12

■ PRODUCT LINE UP

Part No.		MBM29LV004T/MBM29LV004B	
Ordering Part No.	$V_{CC} = 3.3\text{ V}$ $^{+0.3\text{ V}}$ $_{-0.3\text{ V}}$	-10	—
	$V_{CC} = 3.0\text{ V}$ $^{+0.6\text{ V}}$ $_{-0.3\text{ V}}$	—	-12
Max. Address Access Time (ns)		100	120
Max. \overline{CE} Access Time (ns)		100	120
Max. \overline{OE} Access Time (ns)		40	50

■ BLOCK DIAGRAM

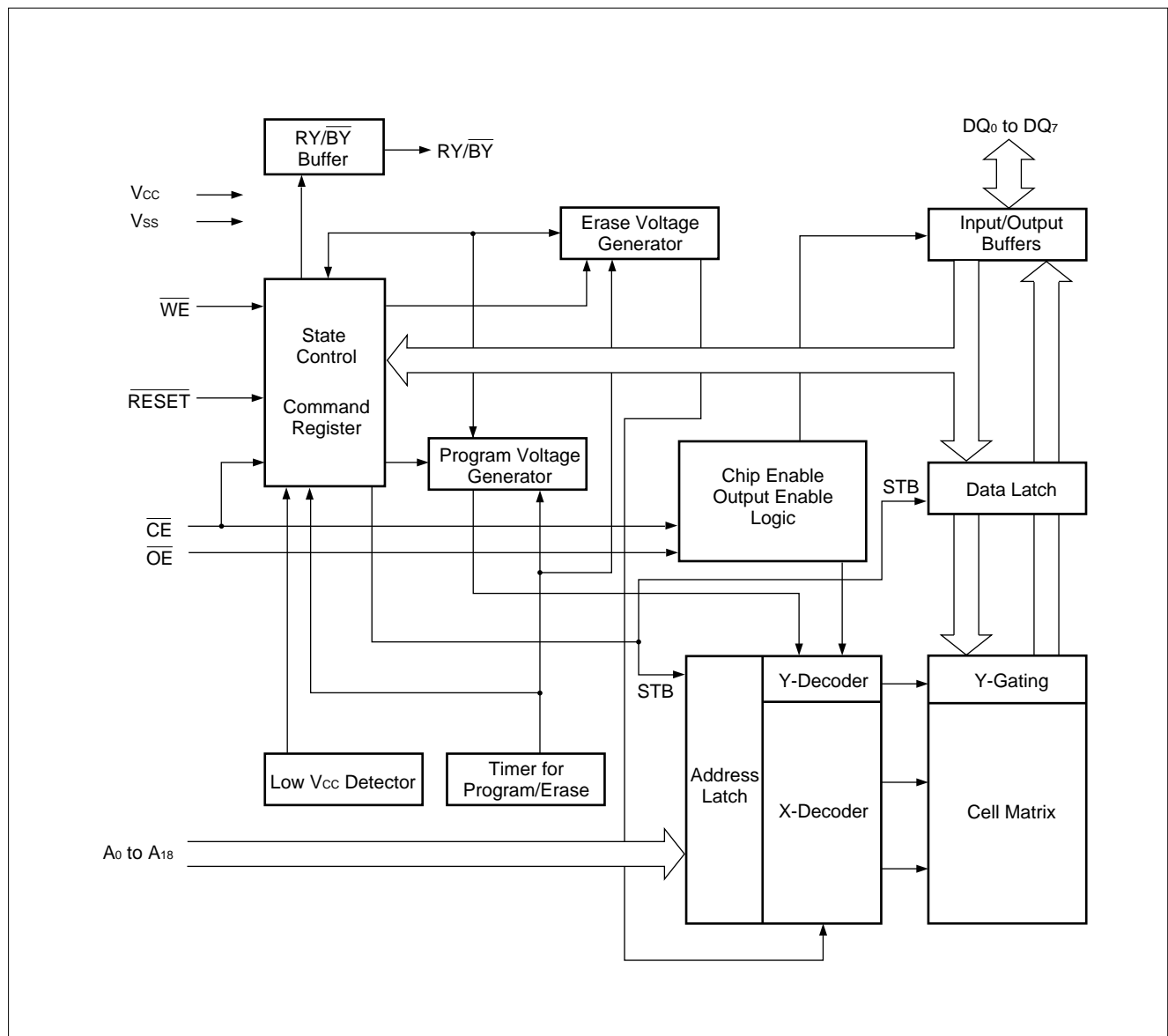

MBM29LV004T-10/-12/MBM29LV004B-10/-12

CONNECTION DIAGRAMS

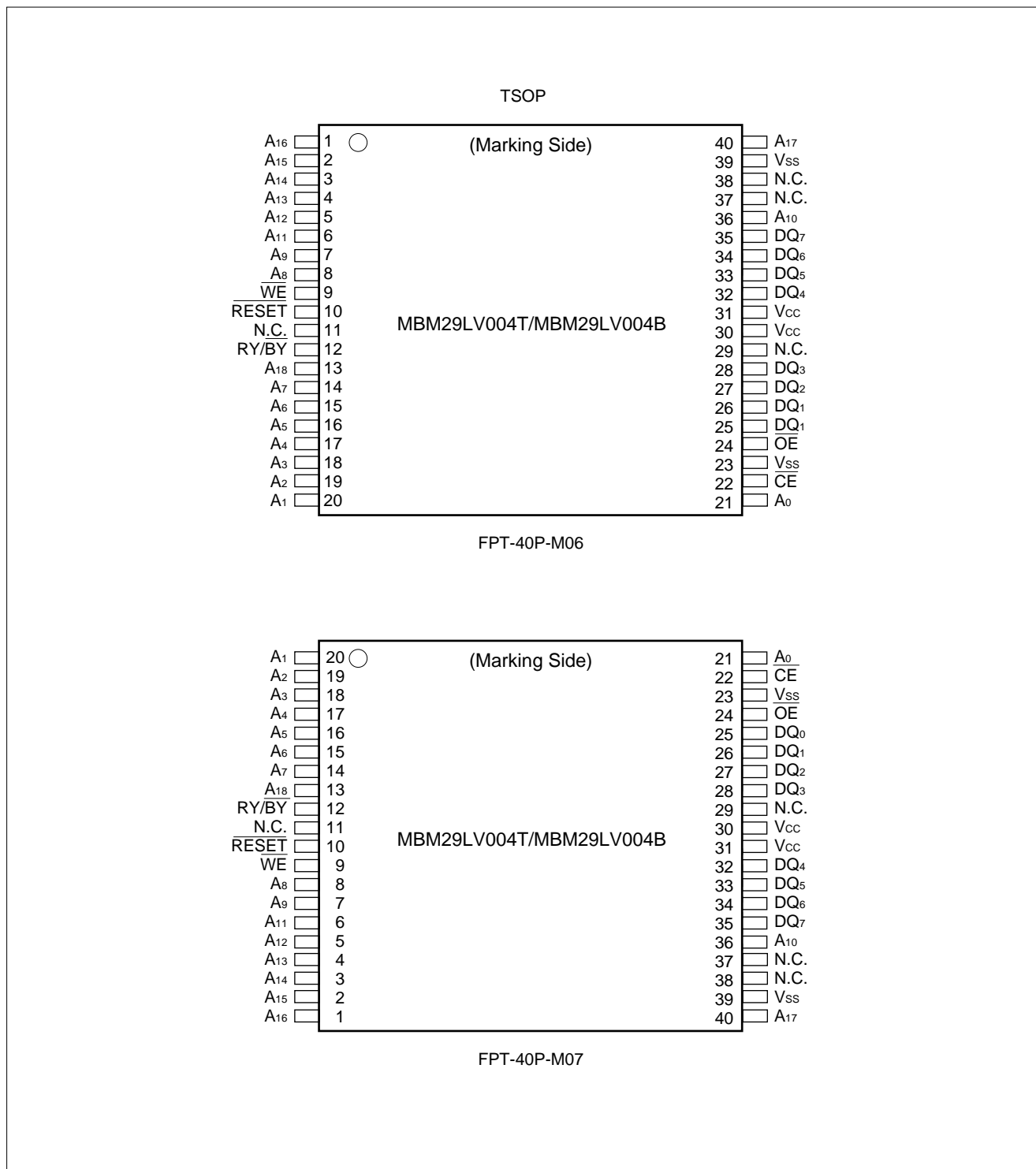

(Continued)

MBM29LV004T-10/-12/MBM29LV004B-10/-12

(Continued)

(TOP VIEW)

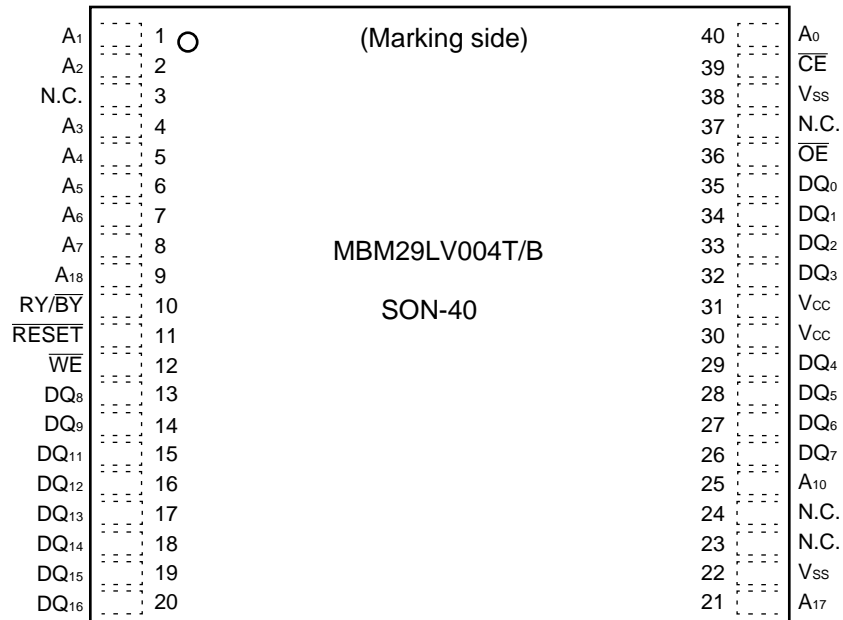

LCC-40P-M02

MBM29LV004T-10/-12/MBM29LV004B-10/-12

■ LOGIC SYMBOL

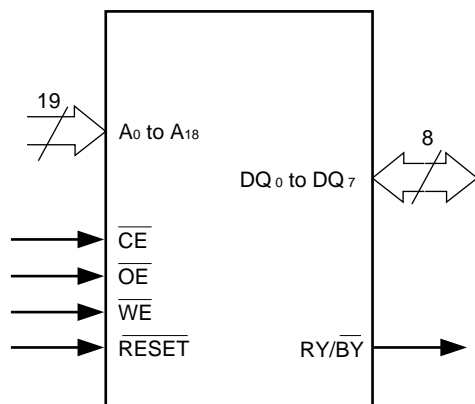

Table 1 MBM29LV004T/004B Pin Configuration

Pin	Function
A ₀ to A ₁₈	Address Inputs
DQ ₀ to DQ ₇	Data Inputs/Outputs
\overline{CE}	Chip Enable
\overline{OE}	Output Enable
\overline{WE}	Write Enable
RY/BY	Ready-Busy Outputs
\overline{RESET}	Hardware Reset Pin/Sector Protection Unlock
N.C.	No Internal Connection
V _{SS}	Device Ground
V _{CC}	Device Power Supply

MBM29LV004T-10/-12/MBM29LV004B-10/-12

■ ORDERING INFORMATION

Standard Products

Fujitsu standard products are available in two packages. The order number is formed by a combination of:

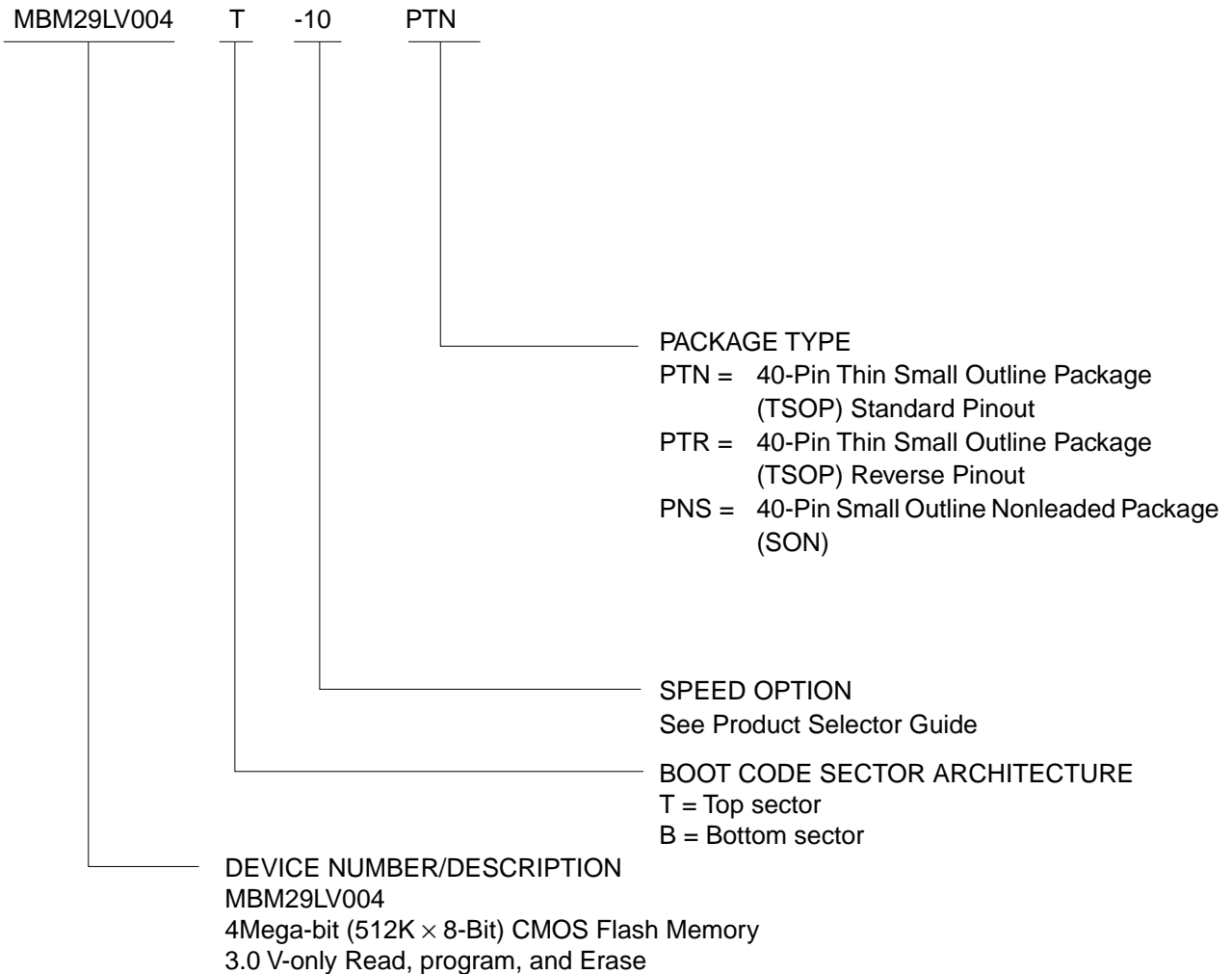

MBM29LV004T-10/-12/MBM29LV004B-10/-12

Table 2 MBM29LV004T/004B User Bus Operations

Operation	\overline{CE}	\overline{OE}	\overline{WE}	A ₀	A ₁	A ₆	A ₉	A ₁₀	DQ ₀ to DQ ₇	\overline{RESET}
Auto-Select Manufacturer Code (1)	L	L	H	L	L	L	V _{ID}	L	Code	H
Auto-Select Device Code (1)	L	L	H	H	L	L	V _{ID}	L	Code	H
Read (2)	L	L	H	A ₀	A ₁	A ₆	A ₉	A ₁₀	D _{OUT}	H
Standby	H	X	X	X	X	X	X	X	HIGH-Z	H
Output Disable	L	H	H	X	X	X	X	X	HIGH-Z	H
Write	L	H	L	A ₀	A ₁	A ₆	A ₉	A ₁₀	D _{IN}	H
Enable Sector Protection (3), (4)	L	V _{ID}	\square	L	H	L	V _{ID}	X	X	H
Verify Sector Protection (3), (4)	L	L	H	L	H	L	V _{ID}	L	Code	H
Temporary Sector Unprotection	X	X	X	X	X	X	X	X	X	V _{ID}
Reset (Hardware)/Standby	X	X	X	X	X	X	X	X	HIGH-Z	L

Legend: L = V_{IL}, H = V_{IH}, X = V_{IL} or V_{IH}, \square = Pulse Input. See DC Characteristics for voltage levels.

- Notes:**
1. Manufacturer and device codes may also be accessed via a command register write sequence. Refer to Table 6.
 2. \overline{WE} can be V_{IL} if \overline{OE} is V_{IL}, \overline{OE} at V_{IH} initiates the write operations.
 3. Refer to the section on Sector Protection.
 4. V_{CC} = 3.3 V ± 10%

FUNCTIONAL DESCRIPTION

Read Mode

The MBM29LV004T/004B have two control functions which must be satisfied in order to obtain data at the outputs. \overline{CE} is the power control and should be used for a device selection. \overline{OE} is the output control and should be used to gate data to the output pins if a device is selected.

Address access time (t_{ACC}) is equal to the delay from stable addresses to valid output data. The chip enable access time (t_{CE}) is the delay from stable addresses and stable \overline{CE} to valid data at the output pins. The output enable access time (t_{OE}) is the delay from the falling edge of \overline{OE} to valid data at the output pins. (Assuming the addresses have been stable for at least t_{ACC} - t_{CE} time.)

Standby Mode

There are two ways to implement the standby mode on the MBM29LV004T/004B devices, one using both the \overline{CE} and \overline{RESET} pins, the other via the \overline{RESET} pin only.

When using both pins, a CMOS standby mode is achieved with \overline{CE} and \overline{RESET} inputs both held at V_{CC} ± 0.3 V. Under this condition the current is typically reduced to less than 5 μA. A TTL standby mode (\overline{CE} and \overline{RESET} pins held at V_{IH}), when the current required is reduced to less than 250 μA. The device can be read with standard access time (t_{CE}) from either of these standby modes.

When using the \overline{RESET} pin only, a CMOS standby mode is achieved with \overline{RESET} input held at V_{SS} ± 0.3 V (\overline{CE} = "H" or "L"). Under this condition the current is consumed is less than 5 μA. A TTL standby mode is achieved with \overline{RESET} pin held at V_{IL} (\overline{CE} = "H" or "L"), when the current required is reduced to less than 250 μA. Once the \overline{RESET} pin is taken high, the device requires 500 ns of wake up time before outputs are valid for read access.

In the standby mode the outputs are in the high impedance state, independent of the \overline{OE} input.

MBM29LV004T-10/-12/MBM29LV004B-10/-12

Automatic Sleep Mode

There is a function called automatic sleep mode to restrain power consumption during read-out of MBM29LV004T/004B data. This mode can be used effectively with an application requested low power consumption such as handy terminals.

To activate this mode, MBM29LV004T/004B automatically switch themselves to low power mode when MBM29LV004T/004B addresses remain stably during access time of 300 ns. It is not necessary to control \overline{CE} , \overline{WE} , and \overline{OE} on the mode. Under the mode, the current consumed is typically 1 μ A (CMOS Level).

Since the data are latched during this mode, the data are read out continuously. If the addresses are changed, the mode is canceled automatically and MBM29LV004T/004B read-out the data for changed addresses.

Output Disable

With the \overline{OE} input at a logic high level (V_{IH}), output from the device is disabled. This will cause the output pins to be in a high impedance state.

Autoselect

The autoselect mode allows the reading out of a binary code from the device and will identify its manufacturer and type. This mode is intended for use by programming equipment for the purpose of automatically matching the device to be programmed with its corresponding Programming Algorithm. This mode is functional over the entire temperature range of the device.

To activate this mode, the programming equipment must force V_{ID} (11.5 V to 12.5 V) on address pin A_9 . Two identifier bytes may then be sequenced from the devices outputs by toggling address A_0 from V_{IL} to V_{IH} . All addresses are DON'T CARES except A_0 , A_1 , A_6 , and A_{10} .

The manufacturer and device codes may also be read via the command register, for instances when the MBM29LV004T/004B are erased or programmed in a system without access to high voltage on the A_9 pin. The command sequence is illustrated in Table 6. (Refer to Autoselect Command section.)

$A_0 = V_{IL}$ represents the manufacturer's code (Fujitsu = 04H) and $A_0 = V_{IH}$ represents the device identifier code (MBM29LV004T = B5H, MBM29LV004B = B6H). All identifiers for manufacturer and device will exhibit odd parity with DQ_7 defined as the parity bit. In order to read the proper device codes when executing the autoselect, A_1 must be V_{IL} . (See Tables 3.1 and 3.2.)

MBM29LV004T-10/-12/MBM29LV004B-10/-12

Table 3.1 MBM29LV004T/004B Sector Protection Verify Autoselect Code

Type		A ₁₈ to A ₁₃	A ₁₀	A ₆	A ₁	A ₀	Code (HEX)
Manufacturer's Code		X	V _{IL}	V _{IL}	V _{IL}	V _{IL}	04H
Device Code	MBM29LV004T	X	V _{IL}	V _{IL}	V _{IL}	V _{IH}	B5H
	MBM29LV004B	X	V _{IL}	V _{IL}	V _{IL}	V _{IH}	B6H
Sector Protection		Sector Addresses	V _{IL}	V _{IL}	V _{IH}	V _{IL}	01H*1

*1: Outputs 01H at protected sector addresses and outputs 00H at unprotected sector addresses.

Table 3.2 Expanded Autoselect Code Table

Type		Code	DQ ₇	DQ ₆	DQ ₅	DQ ₄	DQ ₃	DQ ₂	DQ ₁	DQ ₀
Manufacturer's Code		04H	0	0	0	0	0	1	0	0
Device Code	MBM29LV004T	B5H	1	0	1	1	0	1	0	1
	MBM29LV004B	B6H	1	0	1	1	0	1	1	0
Sector Protection		01H	0	0	0	0	0	0	0	1

Write

Device erasure and programming are accomplished via the command register. The contents of the register serve as inputs to the internal state machine. The state machine outputs dictate the function of the device.

The command register itself does not occupy any addressable memory location. The register is a latch used to store the commands, along with the address and data information needed to execute the command. The command register is written by bringing \overline{WE} to V_{IL}, while \overline{CE} is at V_{IL} and \overline{OE} is at V_{IH}. Addresses are latched on the falling edge of \overline{WE} or \overline{CE} , whichever happens later; while data is latched on the rising edge of \overline{WE} or \overline{CE} , whichever happens first. Standard microprocessor write timings are used.

Refer to AC Write Characteristics and the Erase/Programming Waveforms for specific timing parameters.

Sector Protection

The MBM29LV004T/004B feature hardware sector protection. Those features will disable both program and erase operations in any number of sectors (0 through 10). The sector protection feature is enabled using programming equipment at the user's site. Those devices are shipped with all sectors unprotected.

To activate this mode, the programming equipment must force V_{ID} on address pin A₉ and control pin \overline{OE} , \overline{CE} = V_{IL}, and A₆ = V_{IL}. The sector addresses (A₁₈, A₁₇, A₁₆, A₁₅, A₁₄, and A₁₃) should be set to the sector to be protected. Tables 4 and 5 define the sector address for each of the eleven (11) individual sectors. Programming of the protection circuitry begins on the falling edge of the \overline{WE} pulse and is terminated with the rising edge of the same. Sector addresses must be held constant during the \overline{WE} pulse. Refer to figures 11 and 18 for sector protection waveforms and algorithm.

To verify programming of the protection circuitry, the programming equipment must force V_{ID} on address pin A₉ with \overline{CE} and \overline{OE} at V_{IL} and \overline{WE} at V_{IH}. Scanning the sector addresses (A₁₈, A₁₇, A₁₆, A₁₅, A₁₄, and A₁₃) while (A₁₀, A₆, A₁, A₀) = (0, 0, 1, 0) will produce a logical "1" code at device output DQ₀ for a protected sector. Otherwise the device will read 00H for unprotected sector. In this mode, the lower order addresses, except for A₀, A₁, A₆, and A₁₀ are DON'T CARE. Address locations with A₁ = V_{IL} are reserved for Autoselect manufacturer and device codes.

MBM29LV004T-10/-12/MBM29LV004B-10/-12

It is also possible to determine if a sector is protected in the system by writing an Autoselect command. Performing a read operation at the address location XX02H, where the higher order addresses (A_{18} , A_{17} , A_{16} , A_{15} , A_{14} , and A_{13}) are the sector address will produce a logical "1" at DQ_0 for a protected sector. See Table 3.1 and 3.2 for Autoselect codes.

Temporary Sector Unprotection

This feature allows temporary unprotection of previously protected sectors of the MBM29LV004T/004B devices in order to change data. The Sector Unprotection mode is activated by setting the $\overline{\text{RESET}}$ pin to high voltage ($V_{\text{ID}}=12\text{V}$). During this mode, formerly protected sectors can be programmed or erased by selecting the sector addresses. Once the $V_{\text{ID}}(=12\text{V})$ is taken away from the $\overline{\text{RESET}}$ pin, all the previously protected sectors will be protected again.

$\overline{\text{RESET}}$

Hardware Reset

The MBM29LV004T/004B devices may be reset by driving the $\overline{\text{RESET}}$ pin to V_{IL} . The $\overline{\text{RESET}}$ pin has a pulse requirement and has to be kept low (V_{IL}) for at least 500 ns in order to properly reset the internal state machine. Any operation in the process of being executed will be terminated and the internal state machine will be reset to the read mode 20 μs after the $\overline{\text{RESET}}$ pin is driven low. Furthermore, once the $\overline{\text{RESET}}$ pin goes high, the device requires an additional 50 ns before it will allow read access. When the $\overline{\text{RESET}}$ pin is low, the device will be in the standby mode for the duration of the pulse and all the data output pins will be tri-stated. If a hardware reset occurs during a program or erase operation, the data at that particular location will be corrupted. Please note that the $\text{RY}/\overline{\text{BY}}$ output signal should be ignored during the $\overline{\text{RESET}}$ pulse. Refer to Figure 10 for the timing diagram. Refer to Temporary Sector Unprotection for additional functionality.

If hardware reset occurs during Embedded Erase Algorithm, there is a possibility that the erasing sector(s) cannot be used.

MBM29LV004T-10/-12/MBM29LV004B-10/-12

Table 4 Sector Address Tables (MBM29LV004T)

Sector Address	A ₁₈	A ₁₇	A ₁₆	A ₁₅	A ₁₄	A ₁₃	Address Range
SA0	0	0	0	X	X	X	00000H to 0FFFFH
SA1	0	0	1	X	X	X	10000H to 1FFFFH
SA2	0	1	0	X	X	X	20000H to 2FFFFH
SA3	0	1	1	X	X	X	30000H to 3FFFFH
SA4	1	0	0	X	X	X	40000H to 4FFFFH
SA5	1	0	1	X	X	X	50000H to 5FFFFH
SA6	1	1	0	X	X	X	60000H to 6FFFFH
SA7	1	1	1	0	X	X	70000H to 77FFFH
SA8	1	1	1	1	0	0	78000H to 79FFFH
SA9	1	1	1	1	0	1	7A000H to 7BFFFH
SA10	1	1	1	1	1	X	7C000H to 7FFFFH

Table 5 Sector Address Tables (MBM29LV004B)

Sector Address	A ₁₈	A ₁₇	A ₁₆	A ₁₅	A ₁₄	A ₁₃	Address Range
SA0	0	0	0	0	0	X	00000H to 03FFFH
SA1	0	0	0	0	1	0	04000H to 05FFFH
SA2	0	0	0	0	1	1	06000H to 07FFFH
SA3	0	0	0	1	X	X	08000H to 0FFFFH
SA4	0	0	1	X	X	X	10000H to 1FFFFH
SA5	0	1	0	X	X	X	20000H to 2FFFFH
SA6	0	1	1	X	X	X	30000H to 3FFFFH
SA7	1	0	0	X	X	X	40000H to 4FFFFH
SA8	1	0	1	X	X	X	50000H to 5FFFFH
SA9	1	1	0	X	X	X	60000H to 6FFFFH
SA10	1	1	1	X	X	X	70000H to 7FFFFH

MBM29LV004T-10/-12/MBM29LV004B-10/-12

Table 6 MBM29LV004T/004B Command Definitions

Command Sequence	Bus Write Cycles Req'd	First Bus Write Cycle		Second Bus Write Cycle		Third Bus Write Cycle		Fourth Bus Read/Write Cycle		Fifth Bus Write Cycle		Sixth Bus Write Cycle	
		Addr.	Data	Addr.	Data	Addr.	Data	Addr.	Data	Addr.	Data	Addr.	Data
Read/Reset	1	XXXXH	F0H	—	—	—	—	—	—	—	—	—	—
Read/Reset	3	5555H	AAH	2AAAH	55H	5555H	F0H	RA	RD	—	—	—	—
Autoselect	3	5555H	AAH	2AAAH	55H	5555H	90H	—	—	—	—	—	—
Program	4	5555H	AAH	2AAAH	55H	5555H	A0H	PA	PD	—	—	—	—
Chip Erase	6	5555H	AAH	2AAAH	55H	5555H	80H	5555H	AAH	2AAAH	55H	5555H	10H
Sector Erase	6	5555H	AAH	2AAAH	55H	5555H	80H	5555H	AAH	2AAAH	55H	SA	30H
Sector Erase Suspend	Erase can be suspended during sector erase with Addr ("H" or "L"). Data (B0H)												
Sector Erase Resume	Erase can be resumed after suspend with Addr ("H" or "L"). Data (30H)												

- Notes:**
- Address bits A_{15} to $A_{18} = X = "H"$ or $"L"$ for all address commands except for Program Address (PA) and Sector Address (SA).
 - Bus operations are defined in Table 2.
 - RA = Address of the memory location to be read.
PA = Address of the memory location to be programmed. Addresses are latched on the falling edge of the \overline{WE} pulse.
SA = Address of the sector to be erased. The combination of A_{18} , A_{17} , A_{16} , A_{15} , A_{14} , and A_{13} will uniquely select any sector.
 - RD = Data read from location RA during read operation.
PD = Data to be programmed at location PA.
 - Both Read/Reset commands are functionally equivalent, resetting the device to the read mode.

Command Definitions

Device operations are selected by writing specific address and data sequences into the command register. Writing incorrect address and data values or writing them in the improper sequence will reset the device to read mode. Table 7 defines the valid register command sequences. Note that the Erase Suspend (B0H) and Erase Resume (30H) commands are valid only while the Sector Erase operation is in progress. Moreover both Read/Reset commands are functionally equivalent, resetting the device to the read mode.

Read/Reset Command

The read or reset operation is initiated by writing the Read/Reset command sequence into the command register. Microprocessor read cycles retrieve array data from the memory. The device remains enabled for reads until the command register contents are altered.

The device will automatically power-up in the Read/Reset state. In this case, a command sequence is not required to read data. Standard microprocessor read cycles will retrieve array data. This default value ensures that no spurious alteration of the memory content occurs during the power transition. Refer to the AC Read Characteristics and Waveforms for the specific timing parameters.

MBM29LV004T-10/-12/MBM29LV004B-10/-12

Autoselect Command

Flash memories are intended for use in applications where the local CPU alters memory contents. As such, manufacture and device codes must be accessible while the device resides in the target system. PROM programmers typically access the signature codes by raising A_9 to a high voltage. However, multiplexing high voltage onto the address lines is not generally desired system design practice.

The device contains an Autoselect command operation to supplement traditional PROM programming methodology. The operation is initiated by writing the autoselect command sequence into the command register. Following the command write, a read cycle from address X000H retrieves the manufacture code of 04H. A read cycle from address X001H returns the device code (MBM29LV004T = B5H, MBM29LV004B = B6H) (See Tables 3.1 and 3.2.). All manufacturer and device codes will exhibit odd parity with the MSB (DQ_7) defined as the parity bit.

Sector state (protection or unprotection) will be informed by address X002H.

Scanning the sector addresses ($A_{18}, A_{17}, A_{16}, A_{15}, A_{14}, A_{13}$) while (A_{10}, A_6, A_1, A_0) = (0, 0, 1, 0) will produce a logical "1" at device output DQ_0 for a protected sector.

To terminate the operation, it is necessary to write the Read/Reset command sequence into the register, and also to write the autoselect command during the operation, execute it after writing read/reset command sequence.

Byte Programming

The device is programmed on a byte-by-byte basis. Programming is a four bus cycle operation. There are two "unlock" write cycles. These are followed by the program set-up command and data write cycles. Addresses are latched on the falling edge of \overline{CE} or \overline{WE} , whichever happens later and the data is latched on the rising edge of \overline{CE} or \overline{WE} , whichever happens first. The rising edge of \overline{CE} or \overline{WE} (whichever happens first) begins programming. Upon executing the Embedded Program Algorithm command sequence, the system is not required to provide further controls or timings. The device will automatically provide adequate internally generated program pulses and verify the programmed cell margin.

The automatic programming operation is completed when the data on DQ_7 is equivalent to data written to this bit at which time the device returns to the read mode and addresses are no longer latched (See Table 7, Hardware Sequence Flags.). Therefore, the device requires that a valid address to the device be supplied by the system at this particular instance of time. Hence, \overline{Data} Polling must be performed at the memory location which is being programmed.

Any commands written to the chip during this period will be ignored. If hardware reset occurs during the programming operation, it is impossible to guarantee the data are being written.

Programming is allowed in any sequence and across sector boundaries. Beware that a data "0" cannot be programmed back to a "1". Attempting to do so will probably hang up the device (exceed timing limits), or perhaps result in an apparent success according to the data polling algorithm but a read from reset/read mode will show that the data is still "0". Only erase operations can convert "0"s to "1"s.

Figure 17 illustrates the Embedded Programming™ Algorithm using typical command strings and bus operations.

Chip Erase

Chip erase is a six bus cycle operation. There are two "unlock" write cycles. These are followed by writing the "set-up" command. Two more "unlock" write cycles are then followed by the chip erase command.

Chip erase does not require the user to program the device prior to erase. Upon executing the Embedded Erase Algorithm command sequence the device will automatically program and verify the entire memory for an all zero data pattern prior to electrical erase (Preprogram function). The system is not required to provide any controls or timings during these operations.

The automatic erase begins on the rising edge of the last \overline{WE} pulse in the command sequence and terminates when the data on DQ_7 is "1" (See Write Operation Status section.) at which time the device returns to read the mode. Chip Erase Time; Sector Erase Time × All sectors + Chip Program Time (Preprogramming).

Figure 18 illustrates the Embedded Erase™ Algorithm using typical command strings and bus operations.

Sector Erase

Sector erase is a six bus cycle operation. There are two “unlock” write cycles. These are followed by writing the “set-up” command. Two more “unlock” write cycles are then followed by the Sector Erase command. The sector address (any address location within the desired sector) is latched on the falling edge of \overline{WE} , while the command (Data=30H) is latched on the rising edge of \overline{WE} . After time-out of 50 μ s from the rising edge of the last Sector Erase command, the sector erase operation will begin.

Multiple sectors may be erased concurrently by writing the six bus cycle operations on Table 7. This sequence is followed with writes of the Sector Erase command to addresses in other sectors desired to be concurrently erased. The time between writes must be less than 50 μ s, otherwise that command will not be accepted and erasure will start. It is recommended that processor interrupts be disabled during this time to guarantee this condition. The interrupts can be re-enabled after the last Sector Erase command is written. A time-out of 50 μ s from the rising edge of the last \overline{WE} will initiate the execution of the Sector Erase command(s). If another falling edge of the \overline{WE} occurs within the 50 μ s time-out window the timer is reset (Monitor DQ₃ to determine if the sector erase timer window is still open, see section DQ₃, Sector Erase Timer). Any command other than Sector Erase or Erase Suspend during this time-out period will reset the device to the read mode, ignoring the previous command string. Resetting the device once execution has begun will corrupt the data in that sector. In that case, restart the erase on those sectors and allow them to complete. (Refer to the Write Operation Status section for Sector Erase Timer operation.) Loading the sector erase buffer may be done in any sequence and with any number of sectors (0 to 10).

Sector erase does not require the user to program the device prior to erase. The device automatically programs all memory locations in the sector(s) to be erased prior to electrical erase (Preprogram function). When erasing a sector or sectors the remaining unselected sectors are not affected. The system is not required to provide any controls or timings during these operations.

The automatic sector erase begins after the 50 μ s time out from the rising edge of the \overline{WE} pulse for the last sector erase command pulse and terminates when the data on DQ₇ is “1” (See Write Operation Status section.) at which time the device returns to the read mode. \overline{Data} polling must be performed at an address within any of the sectors being erased. Multiple Sector Erase Time; [Sector Erase Time + Sector program time (Preprogramming)] \times Number of Sector Erase

Figure 18 illustrates the Embedded Erase™ Algorithm using typical command strings and bus operations.

Erase Suspend

The Erase Suspend command allows the user to interrupt a Sector Erase operation and then perform data reads (not program) from a non-busy sector. This command is applicable ONLY during the Sector Erase operation and will be ignored if written during the Chip Erase or Programming operation. The Erase Suspend command (B0H) will be allowed only during the Sector Erase Operation that will include the sector erase time-out period after the Sector Erase commands (30H). Writing this command during the time-out will result in immediate termination of the time-out period. Any subsequent writes of the Sector Erase command will be taken as the Erase Resume command. Note that any other commands during the time out will reset the device to read mode. The addresses are DON'T CARES when writing the Erase Suspend or Erase Resume commands. When the Erase Suspend command is written during a Sector Erase operation, the device will take a maximum of 20 μ s to suspend the erase operation. When the device has entered the erase-suspended mode, the DQ₇ bit will be at logic “1”, and DQ₆ will stop toggling. The user must use the address of the erasing sector for reading DQ₆ and DQ₇ to determine if the erase operation has been suspended. Further writes of the Erase Suspend command are ignored.

When the erase operation has been suspended, the device defaults to the erase-suspend-read mode. Reading data in this mode is the same as reading from the standard read mode except that the data must be read from sectors that have not been erase-suspended.

To resume the operation of Sector Erase, the Resume command (30H) should be written. Any further writes of the Resume command at this point will be ignore. Another Erase Suspend command can be written after the chip has resumed erasing.

MBM29LV004T-10/-12/MBM29LV004B-10/-12

Write Operation Status

Table 7 Hardware Sequence Flags

Status		DQ ₇	DQ ₆	DQ ₅	DQ ₃	DQ ₂	
In Progress	Embedded Program Algorithm	$\overline{\text{DQ}}_7$	Toggle	0	0	1	
	Embedded Erase Algorithm	0	Toggle	0	1	Toggle	
	Erase Suspended Mode	Erase Suspend Read (Erase Suspended Sector)	1	1	0	0	Toggle (Note 1)
		Erase Suspend Read (Non-Erase Suspended Sector)	Data	Data	Data	Data	Data
	Erase Suspend Program (Non-Erase Suspended Sector)	$\overline{\text{DQ}}_7$	Toggle (Note 2)	0	0	1 (Note 3)	
Exceeded Time Limits	Embedded Program Algorithm	$\overline{\text{DQ}}_7$	Toggle	1	0	1	
	Program/Erase in Embedded Erase Algorithm	0	Toggle	1	1	N/A	
	Erase Suspended Mode	Erase Suspend Program (Non-Erase Suspended Sector)	$\overline{\text{DQ}}_7$	Toggle	1	0	N/A

- Notes:**
1. Performing successive read operations from the erase-suspended sector will cause DQ₂ to toggle.
 2. Performing successive read operations from any address will cause DQ₆ to toggle.
 3. Reading the byte address being programmed while in the erase-suspend program mode will indicate logic “1” at the DQ₂ bit. However, successive reads from the erase-suspended sector will cause DQ₂ to toggle.
 4. DQ₀ and DQ₁ are reserve pins for future use.
 5. DQ₄ is for Fujitsu internal use only.

DQ₇

Data Polling

The MBM29LV004T/004B devices feature $\overline{\text{Data}}$ Polling as a method to indicate to the host that the Embedded Algorithms are in progress or completed. During the Embedded Program Algorithm an attempt to read the device will produce the complement of the data last written to DQ₇. Upon completion of the Embedded Program Algorithm, an attempt to read the device will produce the true data last written to DQ₇. During the Embedded Erase Algorithm, an attempt to read the device will produce a “0” at the DQ₇ output. Upon completion of the Embedded Erase Algorithm an attempt to read the device will produce a “1” at the DQ₇ output. The flowchart for Polling (DQ₇) is shown in Figure 16.

For chip erase and sector erase, the $\overline{\text{Data}}$ Polling is valid after the rising edge of the sixth $\overline{\text{WE}}$ pulse in the six write pulse sequence. $\overline{\text{Data}}$ Polling must be performed at sector address within any of the sectors being erased and not a protected sector. Otherwise, the status may not be valid. Once the Embedded Algorithm operation is close to being completed, the MBM29LV004T/004B data pins (DQ₇) may change asynchronously while the output enable ($\overline{\text{OE}}$) is asserted low. This means that the device is driving status information on DQ₇ at one instant of time and then that byte's valid data at the next instant of time. Depending on when the system samples the DQ₇ output, it may read the status or valid data. Even if the device has completed the Embedded Algorithm operation and DQ₇ has a valid data, the data outputs on DQ₀ to DQ₆ may be still invalid. The valid data on DQ₀ to DQ₇ will be read on the successive read attempts.

The $\overline{\text{Data}}$ Polling feature is only active during the Embedded Programming Algorithm, Embedded Erase Algorithm, or sector erase time-out. (See Table 7.)

See Figure 10 for the $\overline{\text{Data}}$ Polling timing specifications and diagrams.

MBM29LV004T-10/-12/MBM29LV004B-10/-12

DQ₆

Toggle Bit I

The MBM29LV004T/004B also feature the “Toggle Bit I” as a method to indicate to the host system that the Embedded Algorithms are in progress or completed.

During an Embedded Program or Erase Algorithm cycle, successive attempts to read (\overline{OE} toggling) data from the device will result in DQ₆ toggling between one and zero. Once the Embedded Program or Erase Algorithm cycle is completed, DQ₆ will stop toggling and valid data will be read on the next successive attempts. During programming, the Toggle Bit I is valid after the rising edge of the fourth \overline{WE} pulse in the four write pulse sequence. For chip erase and sector erase, the Toggle Bit I is valid after the rising edge of the sixth \overline{WE} pulse in the six write pulse sequence. The Toggle Bit I is active during the sector time out.

In programming, if the sector being written to is protected, the toggle bit I will toggle for about 2 μ s and then stop toggling without the data having changed. In erase, the device will erase all the selected sectors except for the ones that are protected. If all selected sectors are protected, the chip will toggle the toggle bit for about 50 μ s and then drop back into read mode, having changed none of the data.

Either \overline{CE} or \overline{OE} toggling will cause the DQ₆ to toggle. In addition, an Erase Suspend/Resume command will cause DQ₆ to toggle.

See Figure 11 for the Toggle Bit timing specifications and diagrams.

DQ₅

Exceeded Timing Limits

DQ₅ will indicate if the program or erase time has exceeded the specified limits (internal pulse count). Under these conditions DQ₅ will produce a “1”. This is a failure condition which indicates that the program or erase cycle was not successfully completed. \overline{Data} Polling is the only operating function of the device under this condition. The \overline{CE} circuit will partially power down the device under these conditions (to approximately 2 mA). The \overline{OE} and \overline{WE} pins will control the output disable functions as described in Table 2.

If this failure condition occurs during sector erase operation, it specifies that a particular sector is bad and it may not be reused, however, other sectors are still functional and may be used for the program or erase operation. The device must be reset to use other sectors. Write the Reset command sequence to the device, and then execute program or erase command sequence. This allows the system to continue to use the other active sectors in the device.

If this failure condition occurs during the chip erase operation, it specifies that the entire chip is bad or combination of sectors are bad.

If this failure condition occurs during the byte programming operation, it specifies that the entire sector containing that byte is bad and this sector may not be reused. (Other sectors are still functional and can be reused).

The DQ₅ failure condition may also appear if a user tries to program a non blank location without erasing. In this case the device locks out and never completes the Embedded Algorithm operation. Hence, the system never reads a valid data on DQ₇ bit and DQ₆ never stops toggling. Once the device has exceeded timing limits, the DQ₅ bit will indicate a “1.” Please note that this is not a device failure condition since the device was incorrectly used.

DQ₃

Sector Erase Timer

After the completion of the initial Sector Erase command sequence the sector erase time-out will begin. DQ₃ will remain low until the time-out is complete. \overline{Data} Polling and Toggle Bit are valid after the initial Sector Erase command sequence.

If \overline{Data} Polling or the Toggle Bit indicates the device has been written with a valid erase command, DQ₃ may be used to determine if the sector erase timer window is still open. If DQ₃ is high (“1”) the internally controlled erase

MBM29LV004T-10/-12/MBM29LV004B-10/-12

cycle has begun; attempts to write subsequent commands (except erase suspend command) to the device will be ignored until the erase operation is completed as indicated by Data Polling or Toggle Bit. If DQ_3 is low ("0"), the device will accept additional sector erase commands. To insure the command has been accepted, the system software should check the status of DQ_3 prior to and following each subsequent Sector Erase command. If DQ_3 were high on the second status check, the command may not have been accepted.

See Table 7: Hardware Sequence Flags.

DQ₂

Toggle Bit II

This Toggle Bit II, along with DQ_6 , can be used to determine whether the device is in the Embedded Erase Algorithm or in Erase Suspend.

Successive reads from the erasing sector will cause DQ_2 to toggle during the Embedded Erase Algorithm. If the device is in the erase-suspended-read mode, successive reads from the erase-suspended sector will cause DQ_2 to toggle. When the device is in the erase-suspended-program mode, successive reads from the byte address of the non-erase suspended sector will indicate a logic "1" at the DQ_2 bit.

DQ_6 is different from DQ_2 in that DQ_6 toggles only when the standard program or Erase, or Erase Suspend Program operation is in progress.

For example, DQ_2 and DQ_6 can be used together to determine the erase-suspend-read mode. (DQ_2 toggles while DQ_6 does not.) See also Table 7 and Figure 16.

Furthermore, DQ_2 can also be used to determine which sector is being erased. When the device is in the erase mode, DQ_2 toggles if this bit is read from the erasing sector.

RY/ \overline{BY}

Ready/Busy

The MBM29LV004T/004B provide a RY/ \overline{BY} open-drain output pin as a way to indicate to the host system that the Embedded Algorithms are either in progress or completed. If the output is low, the device is busy with either a program or erase operation. If the output is high, the device is ready to accept any read/write or erase operation. When the RY/ \overline{BY} pin is low, the device will not accept any additional program or erase commands. If the MBM29LV004T/004B are placed in an Erase Suspend mode, the RY/ \overline{BY} output will be high. Also, since this is an open drain output, many RY/ \overline{BY} pins can be tied together in parallel with a pull up resistor to V_{CC} .

During programming, the RY/ \overline{BY} pin is driven low after the rising edge of the fourth \overline{WE} pulse. During an erase operation, the RY/ \overline{BY} pin is driven low after the rising edge of the sixth \overline{WE} pulse. The RY/ \overline{BY} pin will indicate a busy condition during the \overline{RESET} pulse. Refer to Figure 12 and 13 for a detailed timing diagram.

Since this is an open-drain output, several RY/ \overline{BY} pins can be tied together in parallel with a pull-up resistor to V_{CC} .

MBM29LV004T-10/-12/MBM29LV004B-10/-12

Data Protection

The MBM29LV004T/004B are designed to offer protection against accidental erasure or programming caused by spurious system level signals that may exist during power transitions. During power up the device automatically resets the internal state machine in the Read mode. Also, with its control register architecture, alteration of the memory contents only occurs after successful completion of specific multi-bus cycle command sequences.

The device also incorporates several features to prevent inadvertent write cycles resulting from V_{CC} power-up and power-down transitions or system noise.

Low V_{CC} Write Inhibit

To avoid initiation of a write cycle during V_{CC} power-up and power-down, a write cycle is locked out for V_{CC} less than 2.5 V (typically 2.4 V). If $V_{CC} < V_{LKO}$, the command register is disabled and all internal program/erase circuits are disabled. Under this condition the device will reset to the Read mode. Subsequent writes will be ignored until the V_{CC} level is greater than V_{LKO} . It is the users responsibility to ensure that the control pins are logically correct to prevent unintentional writes when V_{CC} is above 2.5 V.

If Embedded Erase Algorithm is interrupted, there is possibility that the erasing sector(s) cannot be used.

Write Pulse “Glitch” Protection

Noise pulses of less than 5 ns (typical) on \overline{OE} , \overline{CE} , or \overline{WE} will not initiate a write cycle.

Logical Inhibit

Writing is inhibited by holding any one of $\overline{OE} = V_{IL}$, $\overline{CE} = V_{IH}$, or $\overline{WE} = V_{IH}$. To initiate a write cycle \overline{CE} and \overline{WE} must be a logical zero while \overline{OE} is a logical one.

Power-Up Write Inhibit

Power-up of the device with $\overline{WE} = \overline{CE} = V_{IL}$ and $\overline{OE} = V_{IH}$ will not accept commands on the rising edge of \overline{WE} . The internal state machine is automatically reset to the read mode on power-up.

Handling of SON Package

The metal portion of marking side is connected with internal chip electrically. Please pay attention not to occur electrical connection during operation. In worst case, it may be caused permanent damage to device or system by excessive current.

MBM29LV004T-10/-12/MBM29LV004B-10/-12

■ ABSOLUTE MAXIMUM RATINGS

Storage Temperature	-55°C to +125°C
Ambient Temperature with Power Applied.....	-25°C to +85°C
Voltage with Respect to Ground All pins except A ₉ , \overline{OE} , and \overline{RESET} (Note 1).....	-0.5 V to +V _{CC} +0.5 V
V _{CC} (Note 1)	-0.5 V to +5.5 V
A ₉ , \overline{OE} , and \overline{RESET} (Note 2)	-0.5 V to +13.0 V

- Notes:**
1. Minimum DC voltage on input or I/O pins are -0.5 V. During voltage transitions, inputs may negative overshoot V_{SS} to -2.0 V for periods of up to 20 ns. Maximum DC voltage on output and I/O pins are V_{CC} +0.5 V. During voltage transitions, outputs may positive overshoot to V_{CC} +2.0 V for periods of up to 20 ns.
 2. Minimum DC input voltage on A₉, \overline{OE} , and \overline{RESET} pins are -0.5 V. During voltage transitions, A₉, \overline{OE} , and \overline{RESET} pins may negative overshoot V_{SS} to -2.0 V for periods of up to 20 ns. Maximum DC input voltage on A₉, \overline{OE} , and \overline{RESET} pins are +13.0 V which may positive overshoot to 14.0 V for periods of up to 20 ns.

WARNING: Semiconductor devices can be permanently damaged by application of stress (voltage, current, temperature, etc.) in excess of absolute maximum ratings. Do not exceed these ratings.

■ RECOMMENDED OPERATING RANGES

Commercial Devices

Ambient Temperature (T_A)0°C to +70°C

V_{CC} Supply Voltages for MBM29LV004T-12, /B-12.....+2.7 V to +3.6 V

V_{CC} Supply Voltages for MBM29LV004T-10/B-10.....+3.0 V to +3.6 V

Operating ranges define those limits between which the functionality of the devices are guaranteed.

WARNING: Recommended operating conditions are normal operating ranges for the semiconductor device. All the device's electrical characteristics are warranted when operated within these ranges.

Always use semiconductor devices within the recommended operating conditions. Operation outside these ranges may adversely affect reliability and could result in device failure.

No warranty is made with respect to uses, operating conditions, or combinations not represented on the data sheet. Users considering application outside the listed conditions are advised to contact their FUJITSU representative beforehand.

MBM29LV004T-10/-12/MBM29LV004B-10/-12

■ MAXIMUM OVERSHOOT

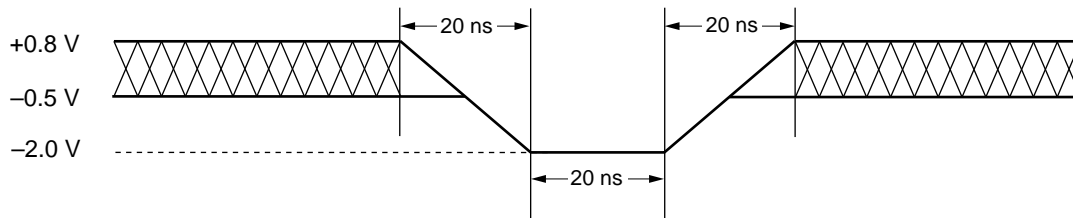

Figure 1 Maximum Negative Overshoot Waveform

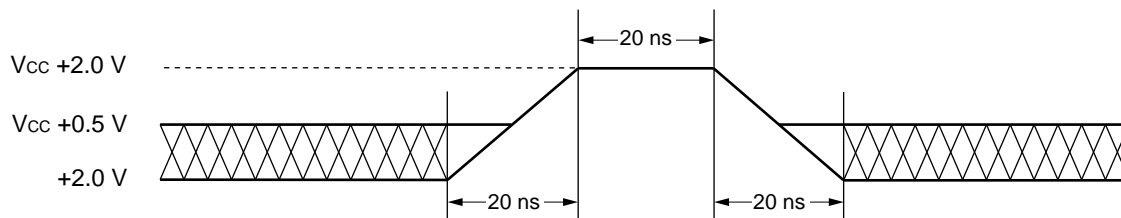
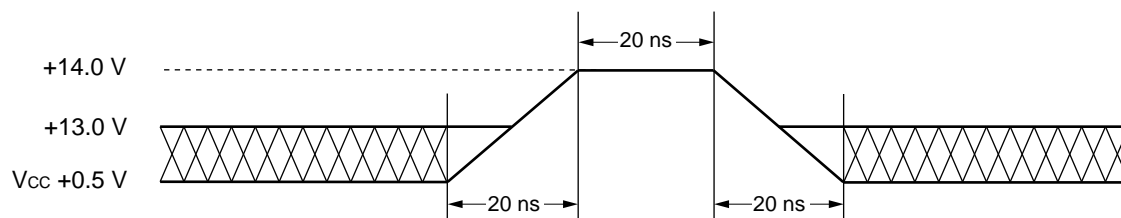

Figure 2 Maximum Positive Overshoot Waveform



* : This waveform is applied for A_9 , \overline{OE} , and \overline{RESET} .

Figure 3 Maximum Positive Overshoot Waveform

MBM29LV004T-10/-12/MBM29LV004B-10/-12

■ DC CHARACTERISTICS

Parameter Symbol	Parameter Description	Test Conditions	Min.	Max.	Unit
I _{LI}	Input Leakage Current	V _{IN} = V _{SS} to V _{CC} , V _{CC} = V _{CC} Max.	-1.0	+1.0	μA
I _{LO}	Output Leakage Current	V _{OUT} = V _{SS} to V _{CC} , V _{CC} = V _{CC} Max.	-1.0	+1.0	μA
I _{LIT}	A ₉ , \overline{OE} , \overline{RESET} Inputs Leakage Current	V _{CC} = V _{CC} Max., A ₉ , \overline{OE} , \overline{RESET} = 12.5 V	—	80	μA
I _{CC1}	V _{CC} Active Current (Note 1)	\overline{CE} = V _{IL} , \overline{OE} = V _{IH}	—	30	mA
I _{CC2}	V _{CC} Active Current (Note 2)	\overline{CE} = V _{IL} , \overline{OE} = V _{IH}	—	35	mA
I _{CC3}	V _{CC} Current (Standby)	V _{CC} = V _{CC} Max., \overline{CE} = V _{CC} ± 0.3 V, \overline{RESET} = V _{CC} ± 0.3 V	—	5	μA
I _{CC4}	V _{CC} Current (Standby, Reset)	V _{CC} = V _{CC} Max., \overline{RESET} = V _{SS} ± 0.3 V	—	5	μA
V _{IL}	Input Low Level	—	-0.5	0.6	V
V _{IH}	Input High Level	—	2.0	V _{CC} + 0.3	V
V _{ID}	Voltage for Autoselect and Sector Protection (A ₉ , \overline{OE} , \overline{RESET})	—	11.5	12.5	V
V _{OL}	Output Low Voltage Level	I _{OL} = 4.0 mA, V _{CC} = V _{CC} Min.	—	0.45	V
V _{OH1}	Output High Voltage Level	I _{OH} = -2.0 mA, V _{CC} = V _{CC} Min.	2.4	—	V
V _{OH2}		I _{OH} = -100 μA, V _{CC} = V _{CC} Min.	V _{CC} - 0.4	—	V
V _{LKO}	Low V _{CC} Lock-Out Voltage	—	2.3	2.5	V

- Notes:**
- The I_{CC} current listed includes both the DC operating current and the frequency dependent component (at 5 MHz).
The frequency component typically is 2 mA/MHz, with \overline{OE} at V_{IH}.
 - I_{CC} active while Embedded Algorithm (program or erase) is in progress.

MBM29LV004T-10/-12/MBM29LV004B-10/-12

■ AC CHARACTERISTICS

• Read Only Operations Characteristics

Parameter Symbols		Description	Test Setup		-10 (Note)	-12 (Note)	Unit
JEDEC	Standard						
t_{AVAV}	t_{RC}	Read Cycle Time	—	Min.	100	120	ns
t_{AVQV}	t_{ACC}	Address to Output Delay	$\overline{CE} = V_{IL}$ $\overline{OE} = V_{IL}$	Max.	100	120	ns
t_{ELQV}	t_{CE}	Chip Enable to Output Delay	$\overline{OE} = V_{IL}$	Max.	100	120	ns
t_{GLQV}	t_{OE}	Output Enable to Output Delay	—	Max.	40	50	ns
t_{EHQZ}	t_{DF}	Chip Enable to Output High-Z	—	Max.	30	30	ns
t_{GHQZ}	t_{DF}	Output Enable to Output High-Z	—	Max.	30	30	ns
t_{AXQX}	t_{OH}	Output Hold Time From Addresses, \overline{CE} or \overline{OE} , Whichever Occurs First	—	Min.	0	0	ns
—	t_{READY}	\overline{RESET} Pin Low to Read Mode	—	Max.	20	20	μs

Note: Test Conditions—Output Load: 1 TTL gate and 30 pF (MBM29LV004T-10/B-10)
1 TTL gate and 100 pF (MBM29LV004T-12, /B-12)

Input rise and fall times: 5 ns

Input pulse levels: 0.0 V to 3.0 V

Timing measurement reference level

Input: 1.5 V

Output: 1.5 V

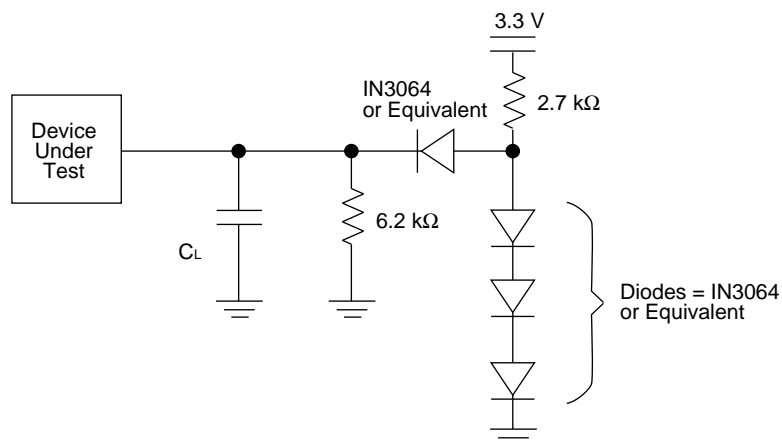

Notes: $C_L = 30$ pF including jig capacitance (MBM29LV004T-10, B-10)
 $C_L = 100$ pF including jig capacitance (MBM29LV004T-12, /B-12)

Figure 4 Maximum Positive Overshoot Waveform

MBM29LV004T-10/-12/MBM29LV004B-10/-12

• Write/Erase/Program Operations Alternate \overline{WE} Controlled Writes

Parameter Symbols		Description		-10	-12	Unit
JEDEC	Standard					
t_{AVAV}	t_{WC}	Write Cycle Time	Min.	100	120	ns
t_{AVWL}	t_{AS}	Address Setup Time	Min.	0	0	ns
t_{WLAX}	t_{AH}	Address Hold Time	Min.	50	50	ns
t_{DVWH}	t_{DS}	Data Setup Time	Min.	50	50	ns
t_{WHDX}	t_{DH}	Data Hold Time	Min.	0	0	ns
—	t_{OES}	Output Enable Setup Time	Min.	0	0	ns
—	t_{OEHL}	Output Enable Hold Time	Min.	0	0	ns
		Read Toggle and \overline{Data} Polling	Min.	10	10	ns
t_{GHWL}	t_{GHWL}	Read Recover Time Before Write	Min.	0	0	ns
t_{ELWL}	t_{CS}	\overline{CE} Setup Time	Min.	0	0	ns
t_{WHEH}	t_{CH}	\overline{CE} Hold Time	Min.	0	0	ns
t_{WLWH}	t_{WP}	Write Pulse Width	Min.	50	50	ns
t_{WHWL}	t_{WPH}	Write Pulse Width High	Min.	30	30	ns
t_{WHWH1}	t_{WHWH1}	Byte Programming Operation	Typ.	8	8	μ s
t_{WHWH2}	t_{WHWH2}	Sector Erase Operation (Note 1)	Typ.	1	1	sec
—	t_{VCS}	V_{CC} Setup Time	Min.	50	50	μ s
—	t_{VLHT}	Voltage Transition Time (Note 2)	Min.	4	4	μ s
—	t_{WPP}	Write Pulse Width (Note 2)	Min.	10	10	μ s
—	t_{OESP}	\overline{OE} Setup Time to \overline{WE} Active (Note 2)	Min.	4	4	μ s
—	t_{CSP}	\overline{CE} Setup Time to \overline{WE} Active (Note 2)	Min.	4	4	μ s
—	t_{RB}	Recover Time From $R\overline{Y}/\overline{B}\overline{Y}$	Min.	0	0	ns
—	t_{RP}	\overline{RESET} Pulse Width	Min.	500	500	ns
—	t_{RH}	\overline{RESET} Hold Time Before Read	Min.	50	50	ns
—	t_{BUSY}	Program/Erase Valid to $R\overline{Y}/\overline{B}\overline{Y}$ Delay	Min.	90	90	ns

- Notes:** 1. This does not include the preprogramming time.
2. These timings are for Sector Protection operation.

MBM29LV004T-10/-12/MBM29LV004B-10/-12

• Write/Erase/Program Operations Alternate CE Controlled Writes





Parameter Symbols		Description		-10	-12	Unit
JEDEC	Standard					
t _{AVAV}	t _{WC}	Write Cycle Time	Min.	100	120	ns
t _{AVEL}	t _{AS}	Address Setup Time	Min.	0	0	ns
t _{ELAX}	t _{AH}	Address Hold Time	Min.	50	50	ns
t _{DVEH}	t _{DS}	Data Setup Time	Min.	50	50	ns
t _{EHDx}	t _{DH}	Data Hold Time	Min.	0	0	ns
—	t _{OES}	Output Enable Setup Time	Min.	0	0	ns
—	t _{OEh}	Output Enable Hold Time	Min.	0	0	ns
		Read Toggle and $\overline{\text{Data}}$ Polling	Min.	10	10	ns
t _{GHEL}	t _{GHEL}	Read Recover Time Before Write	Min.	0	0	ns
t _{WLEL}	t _{WS}	$\overline{\text{WE}}$ Setup Time	Min.	0	0	ns
t _{EHWH}	t _{WH}	$\overline{\text{WE}}$ Hold Time	Min.	0	0	ns
t _{ELEH}	t _{CP}	$\overline{\text{CE}}$ Pulse Width	Min.	50	50	ns
t _{EHEL}	t _{CPH}	$\overline{\text{CE}}$ Pulse Width High	Min.	30	30	ns
t _{WHWH1}	t _{WHWH1}	Byte Programming Operation	Typ.	8	8	μs
t _{WHWH2}	t _{WHWH2}	Sector Erase Operation (Note)	Typ.	1	1	sec
—	t _{VCS}	V _{CC} Setup Time	Min.	50	50	μs
—	t _{RB}	Recover Time From RY/ $\overline{\text{BY}}$	Min.	0	0	ns
—	t _{RP}	$\overline{\text{RESET}}$ Pulse Width	Min.	500	500	ns
—	t _{RH}	$\overline{\text{RESET}}$ Hold Time Before Read	Min.	50	50	ns
—	t _{BUSY}	Program/Erase Valid to RY/ $\overline{\text{BY}}$ Delay	Min.	90	90	ns

Note: This does not include the preprogramming time.

MBM29LV004T-10/-12/MBM29LV004B-10/-12

SWITCHING WAVEFORMS

- Key to Switching Waveforms

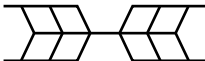
WAVEFORM	INPUTS	OUTPUTS
	Must Be Steady	Will Be Steady
	May Change from H to L	Will Be Changing from H to L
	May Change from L to H	Will Be Changing from L to H
	"H" or "L" Any Change Permitted	Changing, State Unknown
	Does Not Apply	Center Line is High-Impedance "Off" State

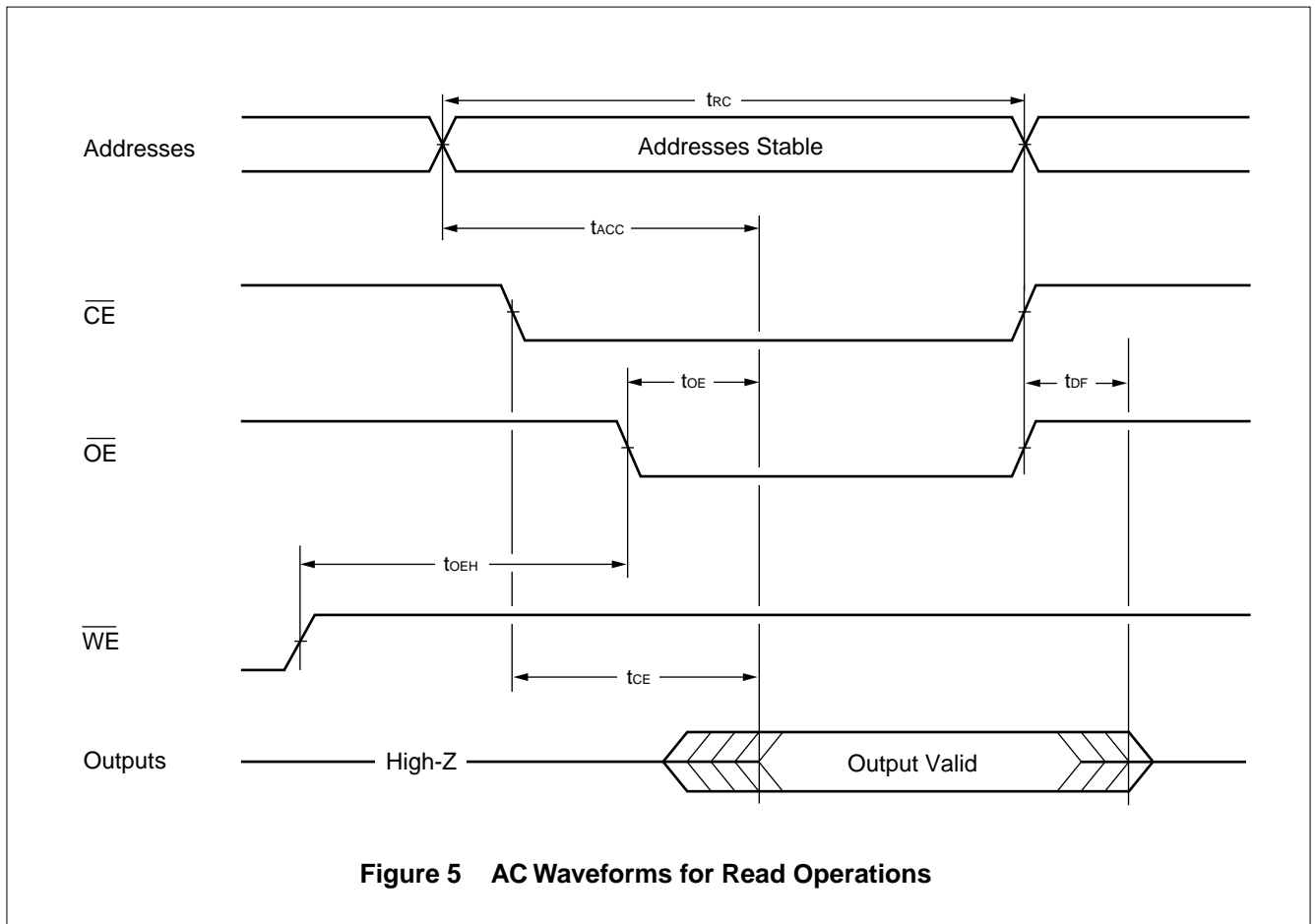
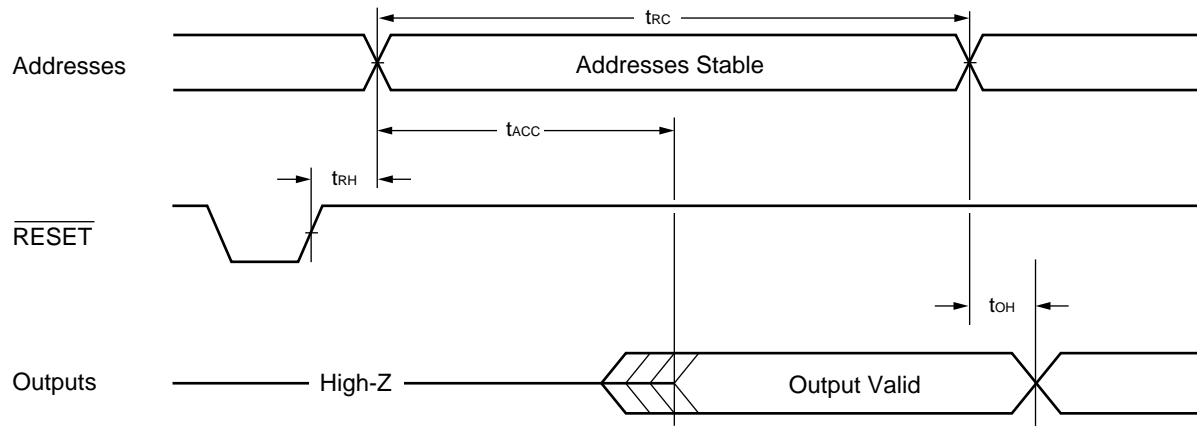
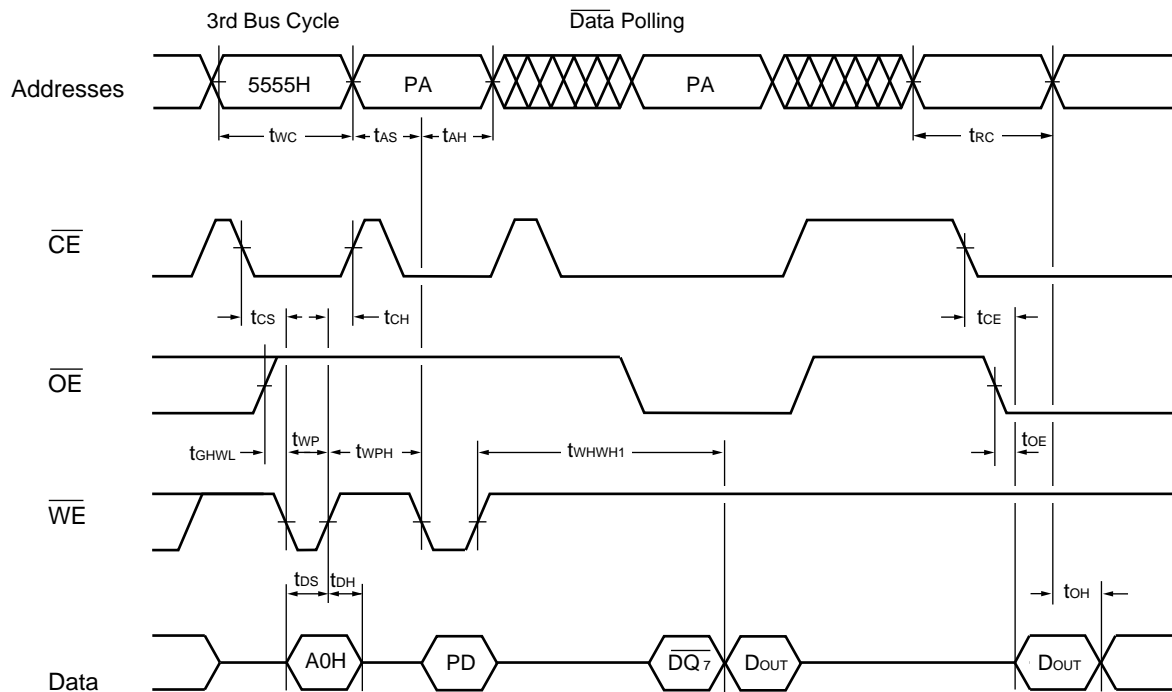

Figure 5 AC Waveforms for Read Operations

MBM29LV004T-10/-12/MBM29LV004B-10/-12**Figure 6 AC Waveforms for Hardware Reset/Read Operations**

MBM29LV004T-10/-12/MBM29LV004B-10/-12



- Notes:**
1. PA is address of the memory location to be programmed.
 2. PD is data to be programmed at byte address.
 3. \overline{DQ}_7 is the output of the complement of the data written to the device.
 4. D_{OUT} is the output of the data written to the device.
 5. Figure indicates last two bus cycles of four bus cycle sequence.

Figure 7 Alternate \overline{WE} Controlled Program Operation Timings

MBM29LV004T-10/-12/MBM29LV004B-10/-12

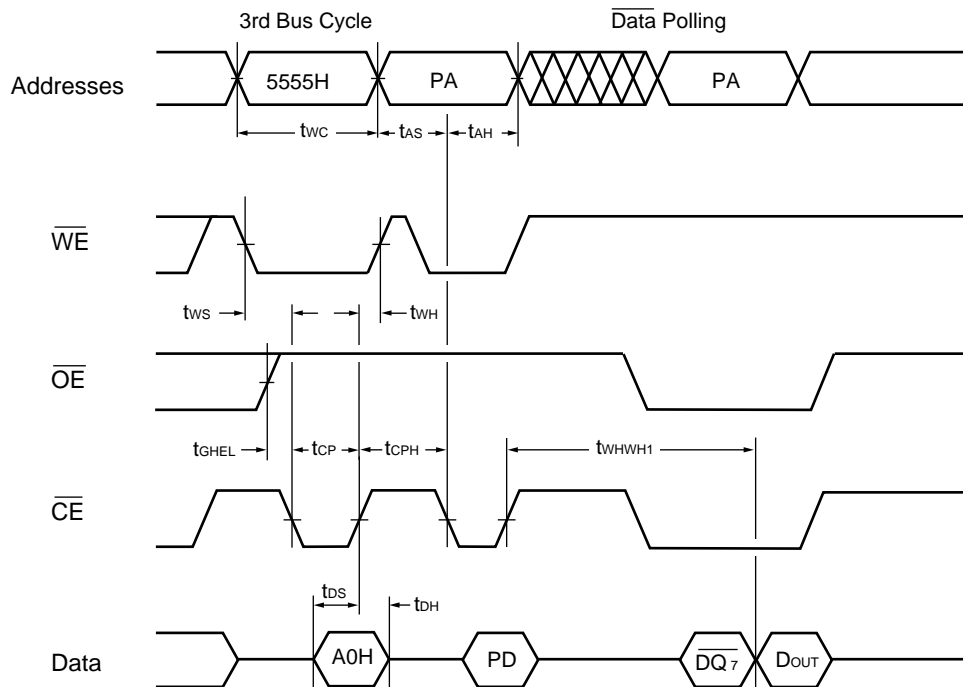

- Notes:**
1. PA is address of the memory location to be programmed.
 2. PD is data to be programmed at byte address.
 3. $\overline{DQ_7}$ is the output of the complement of the data written to the device.
 4. D_{OUT} is the output of the data written to the device.
 5. Figure indicates last two bus cycles of four bus cycle sequence.

Figure 8 Alternate \overline{CE} Controlled Program Operation Timings

MBM29LV004T-10/-12/MBM29LV004B-10/-12

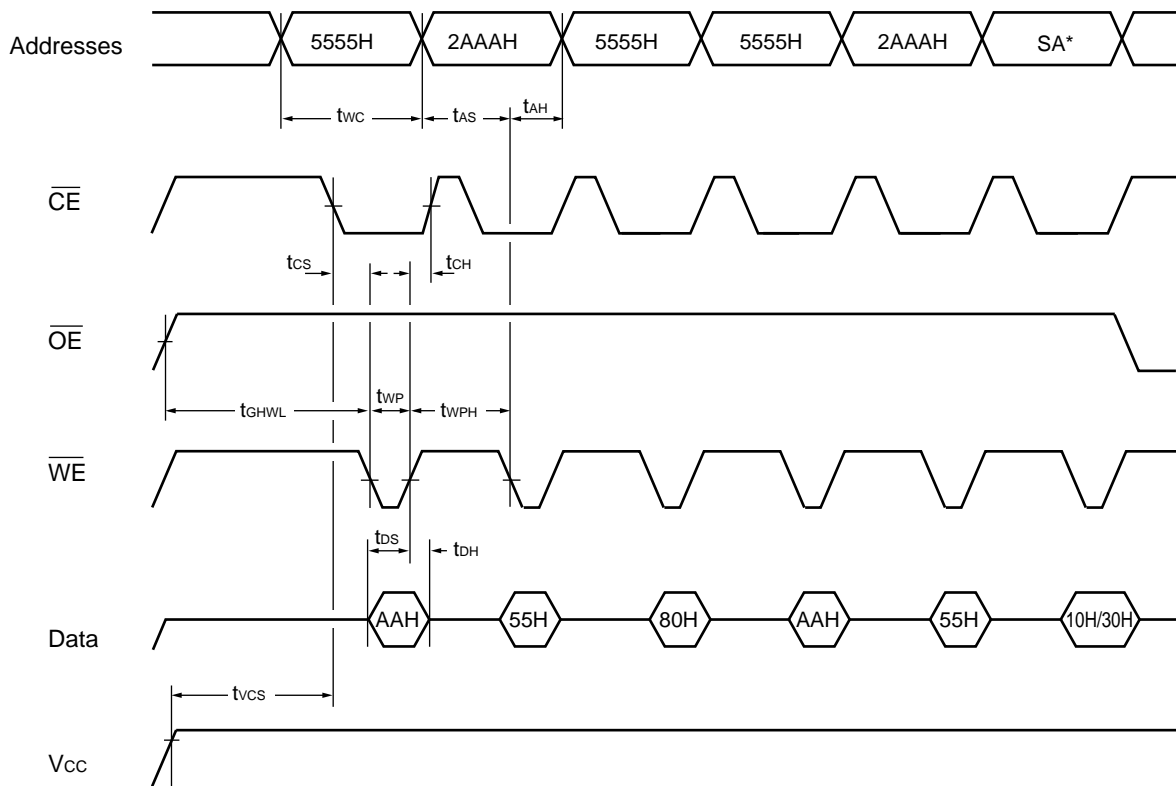

* : SA is the sector address for Sector Erase. Addresses = 5555H for Chip Erase.

Figure 9 AC Waveforms Chip/Sector Erase Operations

MBM29LV004T-10/-12/MBM29LV004B-10/-12

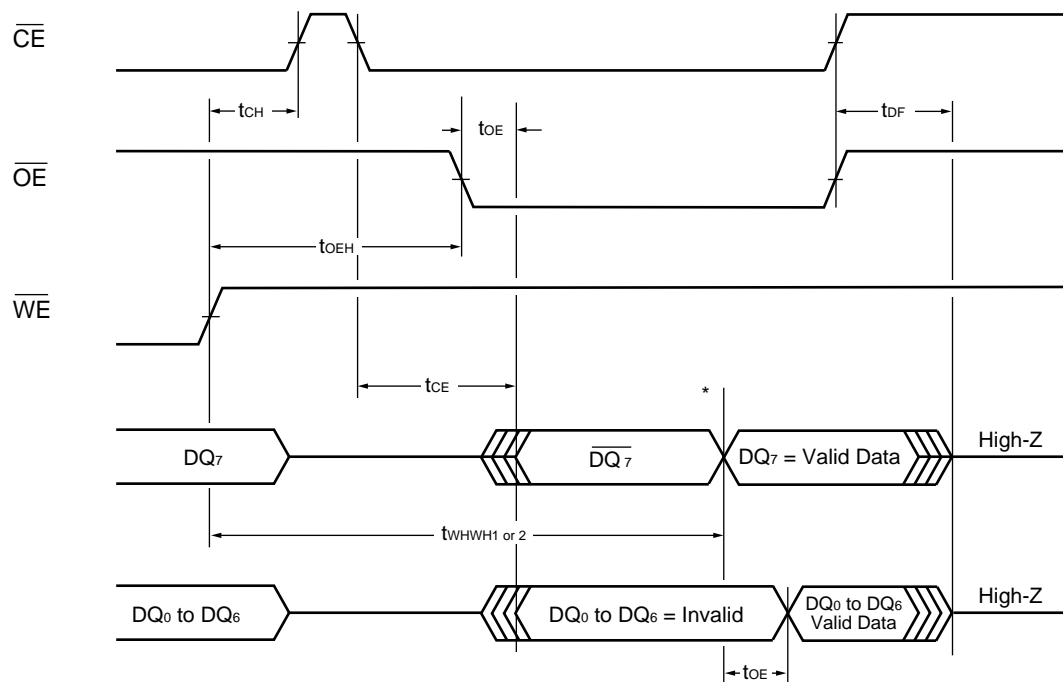

* : DQ_7 = Valid Data (The device has completed the Embedded operation.)

Figure 10 AC Waveforms for Data Polling during Embedded Algorithm Operations

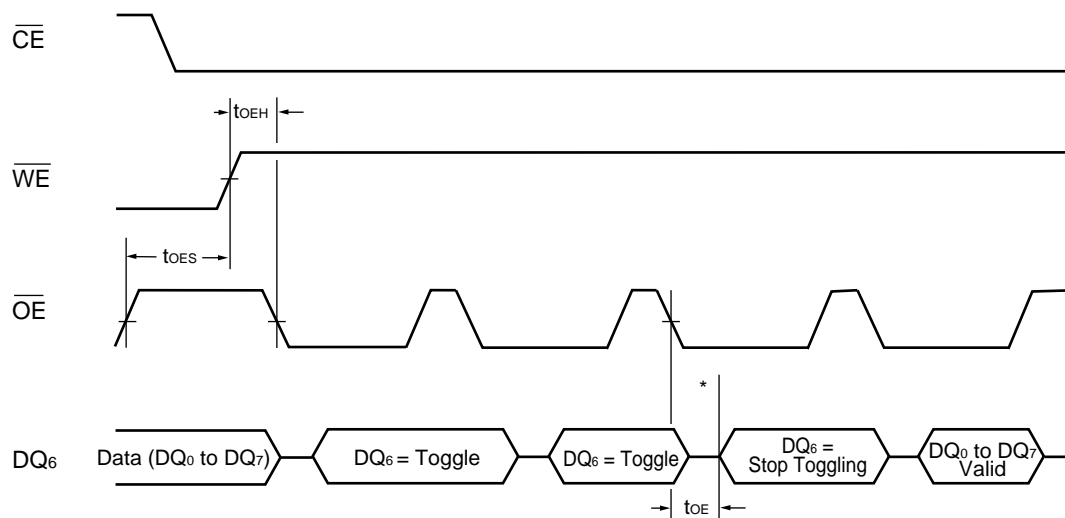

* : DQ_6 stops toggling. (The device has completed the Embedded operation.)

Figure 11 AC Waveforms for Toggle Bit during Embedded Algorithm Operations

MBM29LV004T-10/-12/MBM29LV004B-10/-12

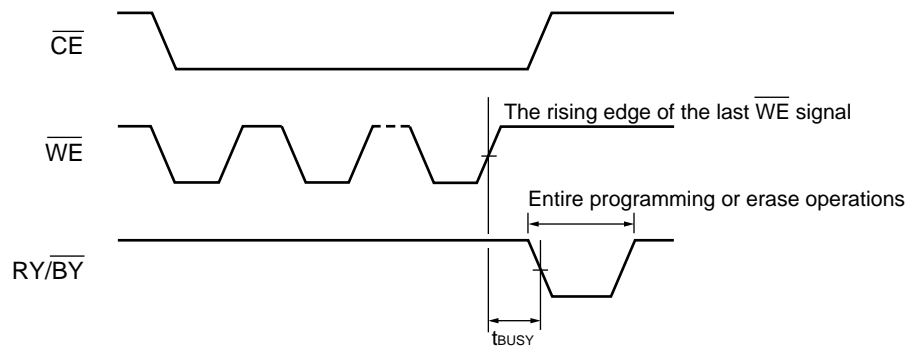

Figure 12 RY/\overline{BY} Timing Diagram during Program/Erase Operations

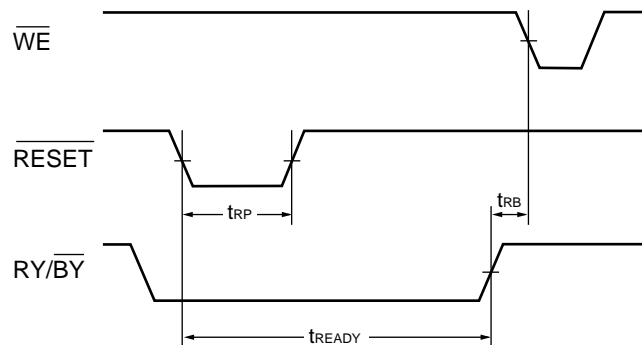
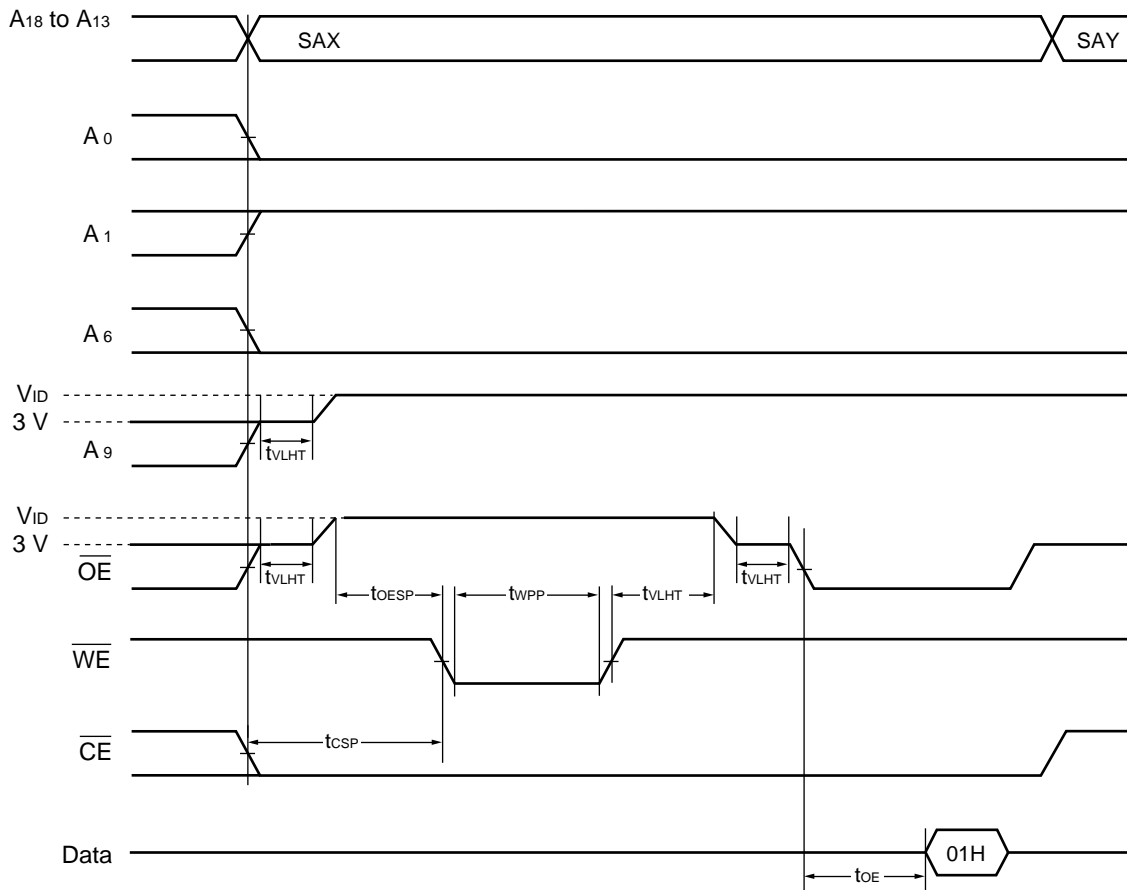

Figure 13 $\overline{RESET}/RY/\overline{BY}$ Timing Diagram

MBM29LV004T-10/-12/MBM29LV004B-10/-12



SAX: Sector Address for initial sector

SAY: Sector Address for next sector

Figure 14 AC Waveforms for Sector Protection

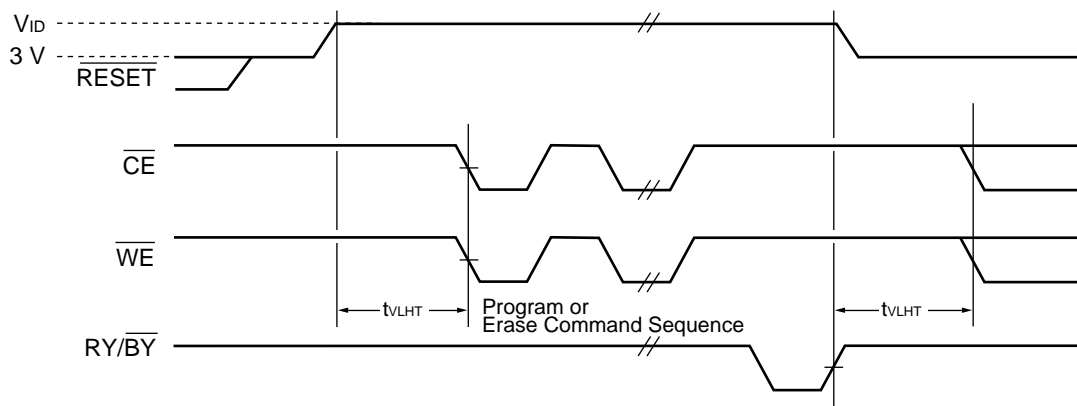
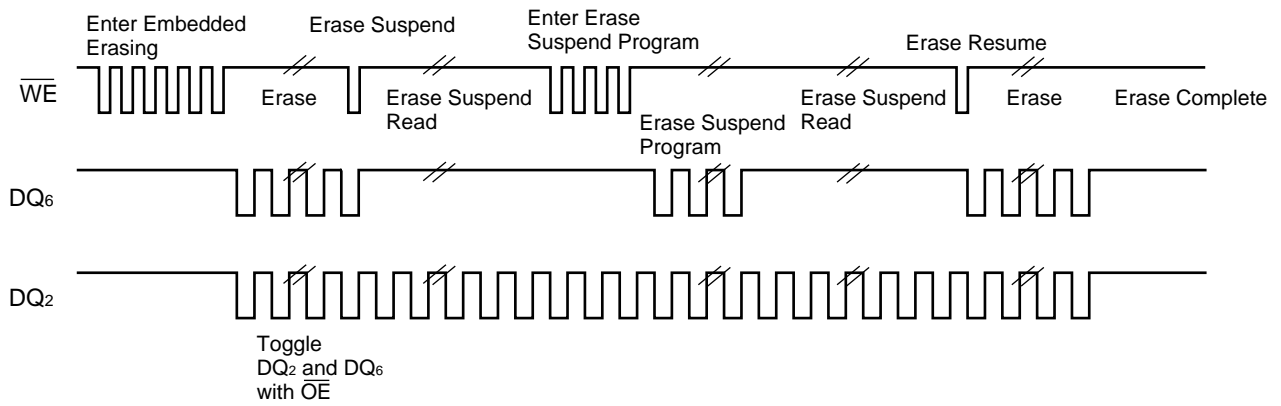

Figure 15 Temporary Sector Unprotection

MBM29LV004T-10/-12/MBM29LV004B-10/-12



Note: DQ_2 is read from the erase-suspended sector.

Figure 16 DQ_2 vs. DQ_6

EMBEDDED ALGORITHMS

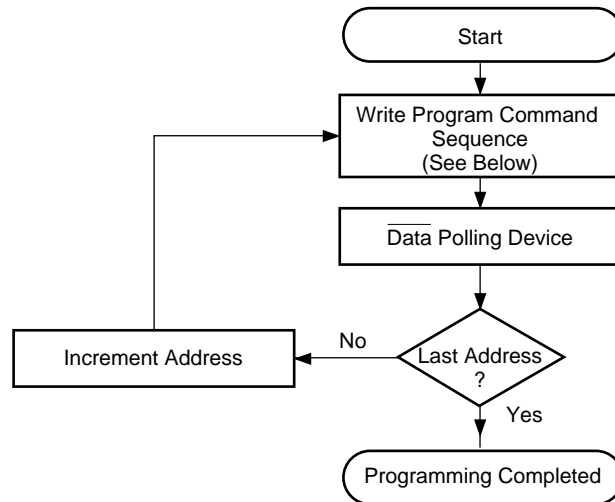

Program Command Sequence (Address/Command):

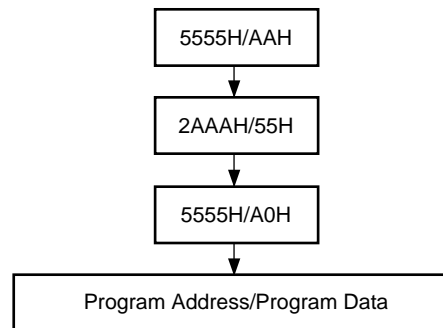

Figure 17 Embedded Programming™ Algorithm

MBM29LV004T-10/-12/MBM29LV004B-10/-12

EMBEDDED ALGORITHMS

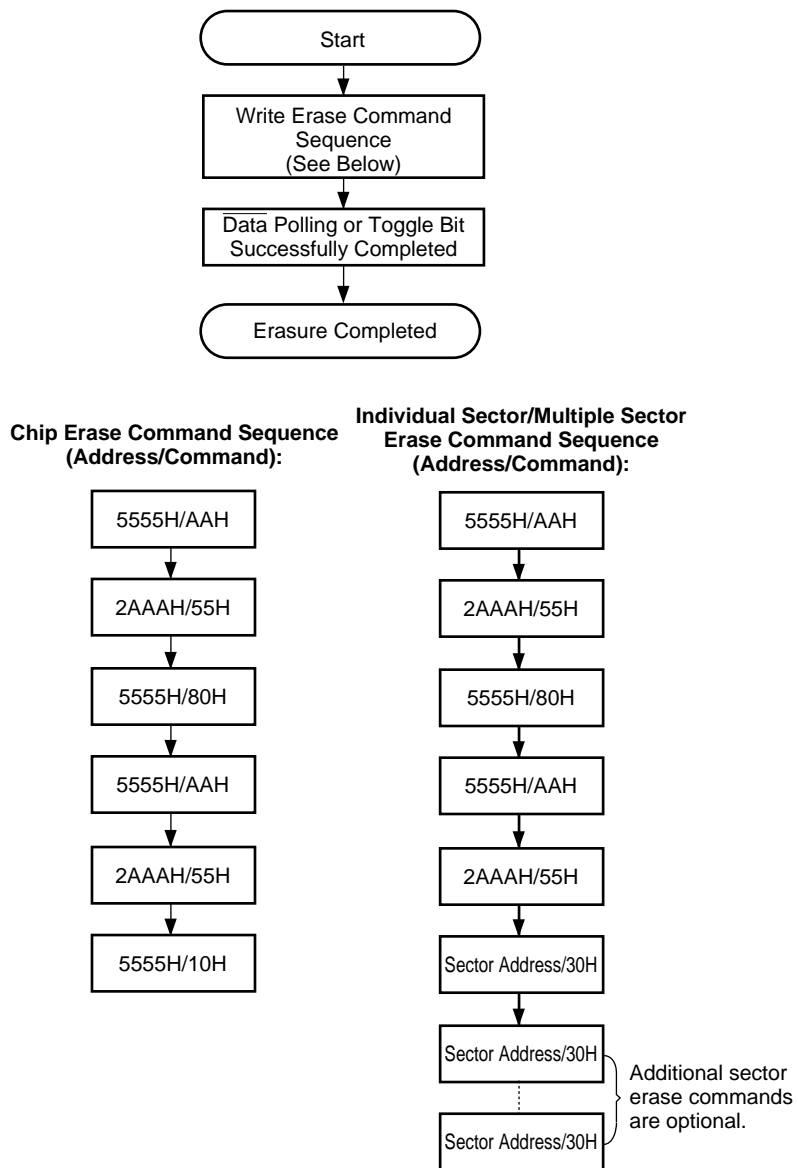
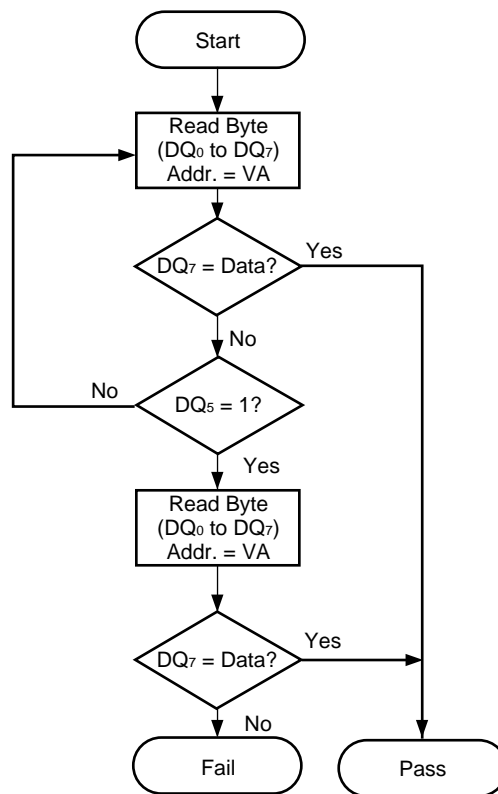

Figure 18 Embedded Erase™ Algorithm

MBM29LV004T-10/-12/MBM29LV004B-10/-12



VA = Byte address for programming
 = Any of the sector addresses within the sector being erased during sector erase or multiple sector erases operation
 = XXXXH during sector erase or multiple sector erases
 = Any of the sector addresses within the sector not being protected during chip erase operation

Note: DQ₇ is rechecked even if DQ₅ = "1" because DQ₇ may change simultaneously with DQ₅.

Figure 19 Data Polling Algorithm

MBM29LV004T-10/-12/MBM29LV004B-10/-12

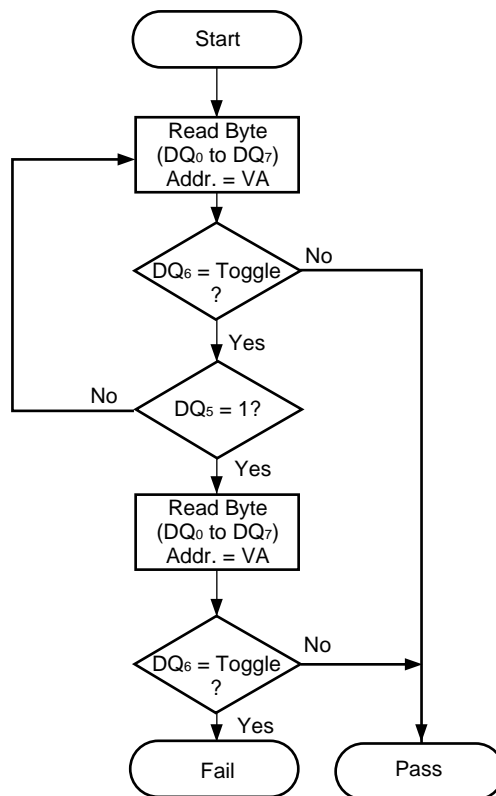

VA = Byte address for programming
 = Any of the sector addresses within the sector being erased during sector erase or multiple sector erases operation
 = XXXXH during sector erase or multiple sector erases
 = Any of the sector addresses within the sector not being protected during chip erase operation

Note: DQ₆ is rechecked even if DQ₅ = "1" because DQ₆ may stop toggling at the same time as DQ₅ changing to "1".

Figure 20 Toggle Bit Algorithm

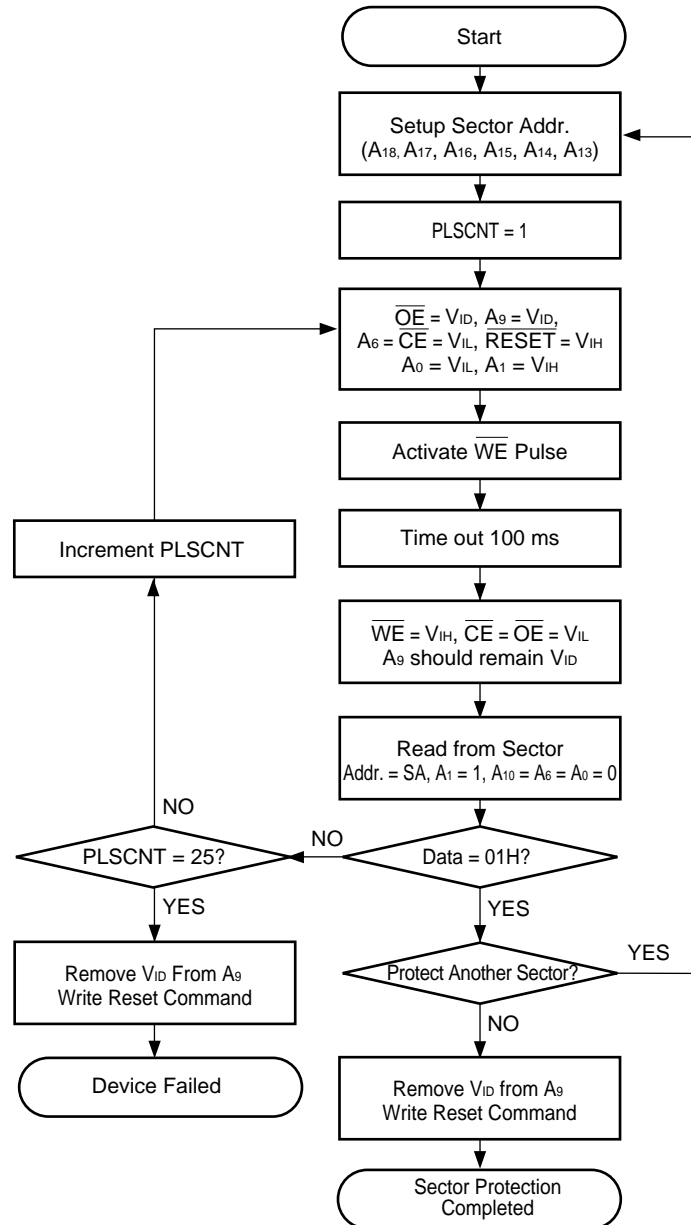
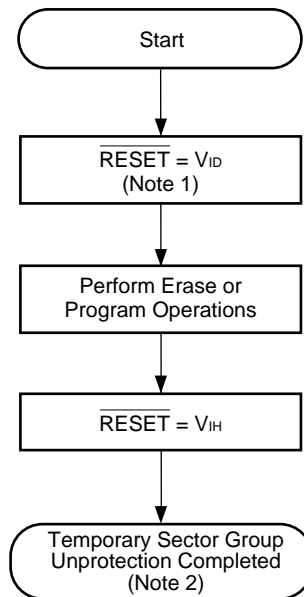

Figure 21 Sector Protection Algorithm



- Notes:**
1. All protected sectors unprotected.
 2. All previously protected sectors are protected once again.

Figure 22 Temporary Sector Unprotection Algorithm

MBM29LV004T-10/-12/MBM29LV004B-10/-12

■ ERASE AND PROGRAMMING PERFORMANCE

Parameter	Limits			Unit	Comment
	Min.	Typ.	Max.		
Sector Erase Time	—	1	15	sec	Excludes programming time prior to erasure
Byte Programming Time	—	8	3,600	μs	Excludes system-level overhead
Chip Programming Time	—	6	T.B.D	sec	Excludes system-level overhead
Erase/Program Cycle	100,000	—	—	Cycles	

■ TSOP PIN CAPACITANCE

Parameter Symbol	Parameter Description	Test Setup	Typ.	Max.	Unit
C _{IN}	Input Capacitance	V _{IN} = 0	7	8	pF
C _{OUT}	Output Capacitance	V _{OUT} = 0	8	10	pF
C _{IN2}	Control Pin Capacitance	V _{IN} = 0	9	11	pF

Note: Test conditions T_A = 25°C, f = 1.0 MHz

■ SON CAPACITANCE

Parameter Symbol	Parameter Description	Test Setup	Typ.	Max.	Unit
C _{IN}	Input Capacitance	V _{IN} = 0	7	8	pF
C _{OUT}	Output Capacitance	V _{OUT} = 0	8	10	pF
C _{IN2}	Control Pin Capacitance	V _{IN} = 0	9	11	pF

Note: Test conditions T_A = 25°C, f = 1.0 MHz

MBM29LV004T-10/-12/MBM29LV004B-10/-12

■ PACKAGE DIMENSIONS

40-pin plastic TSOP (I)
(FPT-40P-M06)

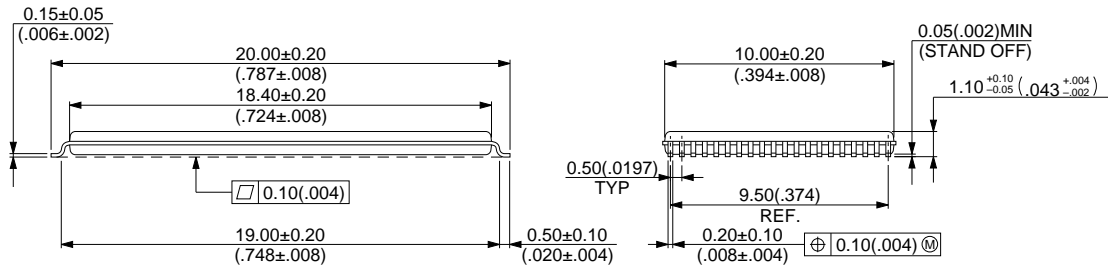
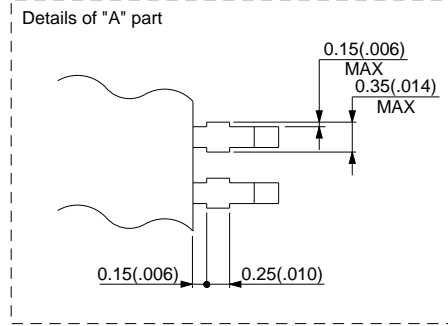
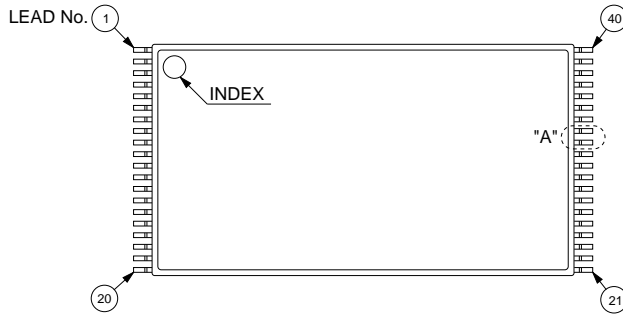

© 1994 FUJITSU LIMITED F40007S-1C-1

Dimensions in mm (inches).

MBM29LV004T-10/-12/MBM29LV004B-10/-12

40-pin plastic TSOP (I)
(FPT-40P-M07)

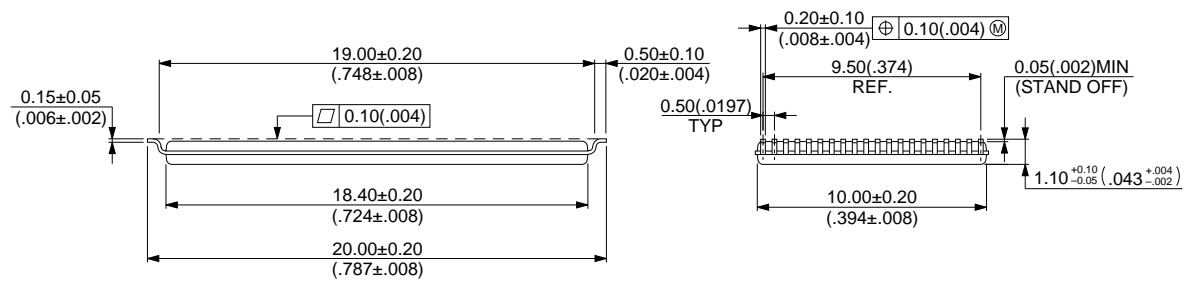
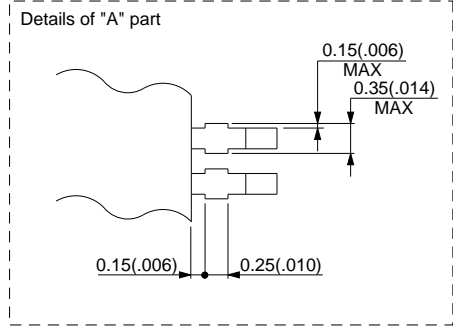
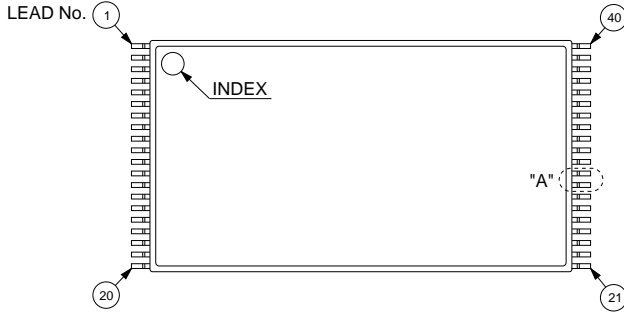

© 1994 FUJITSU LIMITED F40008S-1C-1

Dimensions in mm (inches).

MBM29LV004T-10/-12/MBM29LV004B-10/-12

40-pin Plastic SON (LCC-40P-M02)

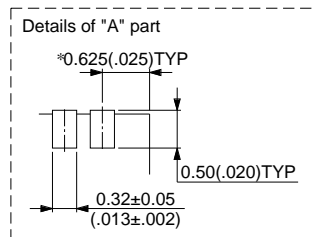
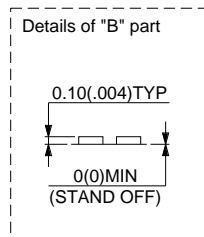
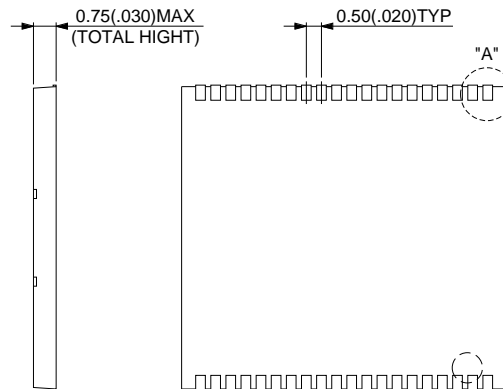
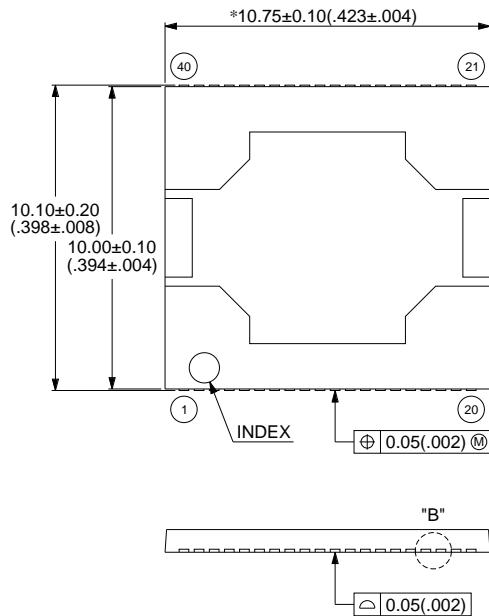

FUJITSU LIMITED

For further information please contact:

Japan

FUJITSU LIMITED
Corporate Global Business Support Division
Electronic Devices
KAWASAKI PLANT, 4-1-1, Kamikodanaka
Nakahara-ku, Kawasaki-shi
Kanagawa 211-88, Japan
Tel: (044) 754-3763
Fax: (044) 754-3329

North and South America

FUJITSU MICROELECTRONICS, INC.
Semiconductor Division
3545 North First Street
San Jose, CA 95134-1804, U.S.A.
Tel: (408) 922-9000
Fax: (408) 432-9044/9045

Europe

FUJITSU MIKROELEKTRONIK GmbH
Am Siebenstein 6-10
63303 Dreieich-Buchsschlag
Germany
Tel: (06103) 690-0
Fax: (06103) 690-122

Asia Pacific

FUJITSU MICROELECTRONICS ASIA PTE. LIMITED
#05-08, 151 Lorong Chuan
New Tech Park
Singapore 556741
Tel: (65) 281-0770
Fax: (65) 281-0220

All Rights Reserved.

The contents of this document are subject to change without notice. Customers are advised to consult with FUJITSU sales representatives before ordering.

The information and circuit diagrams in this document presented as examples of semiconductor device applications, and are not intended to be incorporated in devices for actual use. Also, FUJITSU is unable to assume responsibility for infringement of any patent rights or other rights of third parties arising from the use of this information or circuit diagrams.

FUJITSU semiconductor devices are intended for use in standard applications (computers, office automation and other office equipment, industrial, communications, and measurement equipment, personal or household devices, etc.).

CAUTION:

Customers considering the use of our products in special applications where failure or abnormal operation may directly affect human lives or cause physical injury or property damage, or where extremely high levels of reliability are demanded (such as aerospace systems, atomic energy controls, sea floor repeaters, vehicle operating controls, medical devices for life support, etc.) are requested to consult with FUJITSU sales representatives before such use. The company will not be responsible for damages arising from such use without prior approval.

Any semiconductor devices have inherently a certain rate of failure. You must protect against injury, damage or loss from such failures by incorporating safety design measures into your facility and equipment such as redundancy, fire protection, and prevention of over-current levels and other abnormal operating conditions.

If any products described in this document represent goods or technologies subject to certain restrictions on export under the Foreign Exchange and Foreign Trade Control Law of Japan, the prior authorization by Japanese government should be required for export of those products from Japan.